

1.	General Description	2
2.	Sequence of Operation	2
3.	Motion law diagrams	3
4.	Direction of rotation of the Gripper Arm	4
5.	Danger area	4
6.	Examples of applications	5
7.	System components	5
8.	Sizing and selection	5
9.	Using self-braking motor	6
10.	Clutch Torque Limiter	6
11.	Versions	6
12.	Mounting positions of the Reduction Gear	7
13.	Technical characteristics	7
14.	Overall dimensions	8
15.	Precision	11
16.	Mounting and use of Limit Switches and Cams	11
17.	Description of the Gripper arms	12
18.	Dimensions of Gripper arm	12
19.	Type of Tool Taper	13
20.	Designation	14
21.	Instruction for correct operation	15
22.	Mounting and instructions	15
23.	Maintenance	15

The units of measurement correspond with System International /Severity Index SI General tolerances of manufacture are conform to UNI – ISO 2768-1 UNI EN 22768-1
 Illustrations and drawings according to UNI 3970 (ISO 128-82).

Method of projection of the drawings.

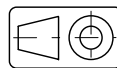

All rights reserved. No part of this catalogue may be duplicated.

COLOMBO FILIPPETTI may make any changes they feel necessary for the improvement of their products without advance notice.

COLOMBO FILIPPETTI may change any market components and accessories mentioned in this catalogue as they feel necessary.

This catalogue supersedes all earlier ones.

HTC140•HTC40•HTC50

1. General

The HTC devices manufactured by COLOMBO FILIPPETTI are mechanical and totally autonomous tool changing units, which, by means of a cam mechanism, turn the incoming uniform rotary movement, supplied by a gear reducer, into a series of intermittent linear and rotary motions of the output shaft, on which the gripper arm is attached. The synchronous combination of the movements carried out by the gripper arm accomplishes the typical tool changing.

The simplicity of its design, the direct transformation of the motions by mechanical cam systems controls the accelerations of the intermittent movements and ensures a positive command during the entire cycle, have all contributed to the realization of this product, whose main features are: accuracy, speed, gentle movements, low vibrations, noiselessness and versatility of application with extremely small overall dimensions. Best results are obtained by specific study directed towards optimisation of the HTC characteristics and with the characteristics of the machine tool. For this reason, it is difficult to have standardization of all dimensions. However, in this catalogue we have tried to present most.

2. Sequence of Cycle motions

The Angle of rotation of the gripper arm from park position to extraction of tool is 90° , if required it can be 60° (degrees). Exchange rotation is 180° . The standard extraction and insertion stroke varies in dimension as indicated in Tab. 4.

Fig. 1 Sequence of Tool Changing cycle

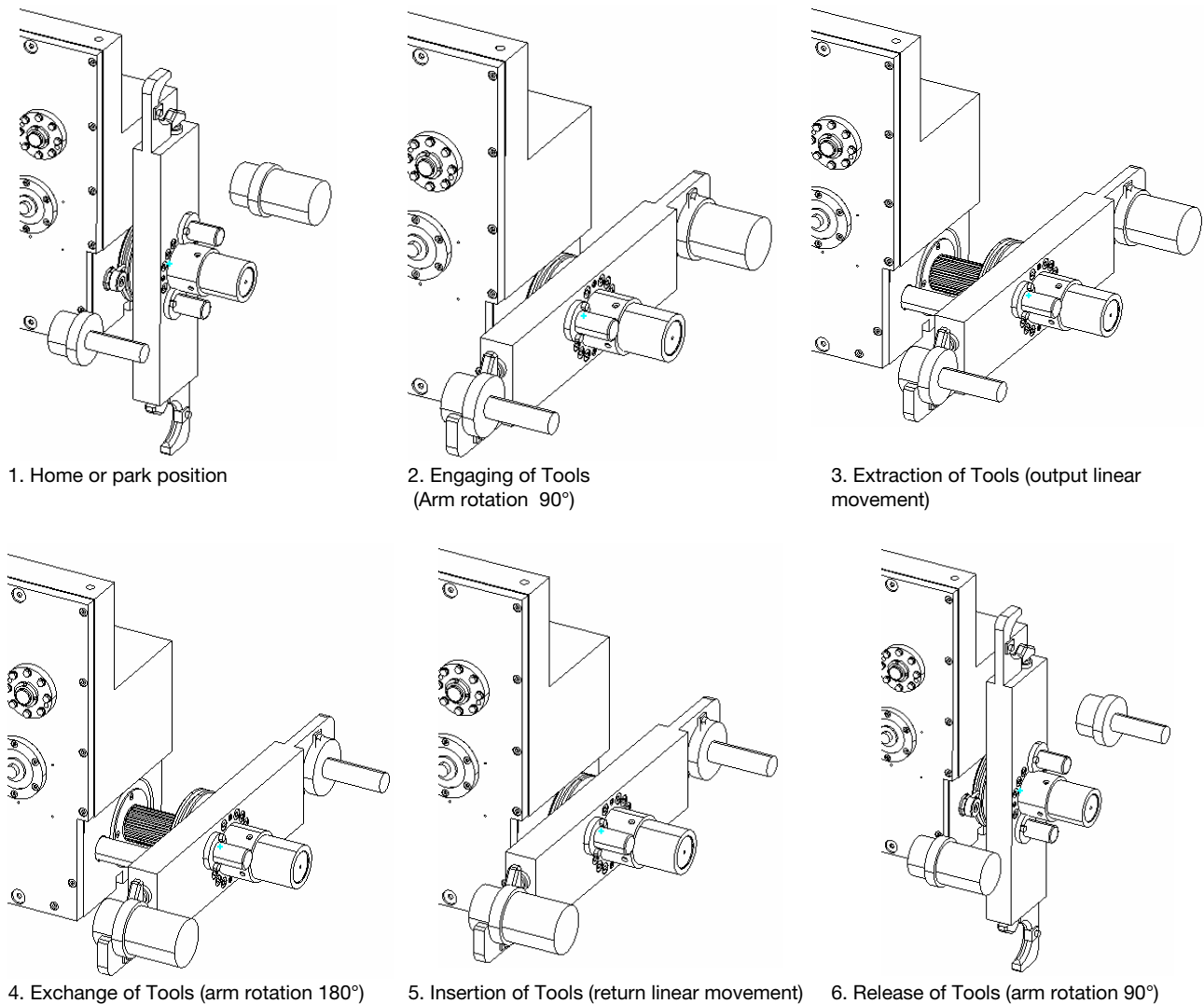

3. Motion law diagram

The diagram below is schematic and does not consider motion laws that are used for the execution of profiles. The optimisation of motion for a particular tool changer may have different profiles and time cycles than those represented.

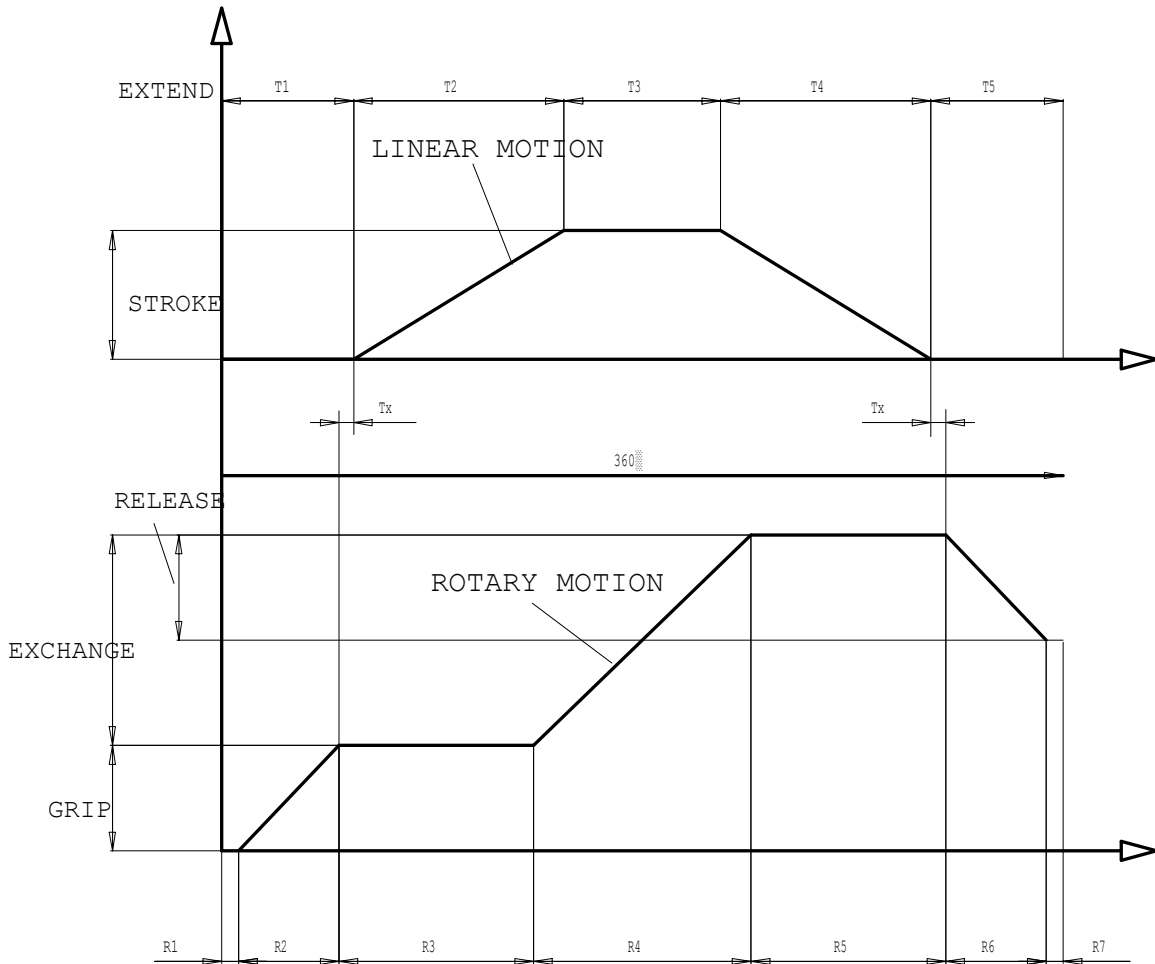

fig. 2 Motion law diagram

Cycle times

T1 = Dwell for arm rotation
 T2 = Extraction travel
 T3 = Dwell during tool exchange
 T4 = Tools insertion travel
 T5 = Dwell for release rotation

Tx = Dwell drawbar clamp/release

R1 = Cycle start dwell
 R2 = Arm rotation for tool engagement
 R3 = Dwell for tool extraction
 R4 = Arm rotation for tool exchange
 R5 = Dwell for tool insertion
 R6 = Arm rotation to park position
 R7 = Cycle end dwell

HTC140•HTC40•HTC50

4. Direction of rotation of the gripper arm

The STANDARD direction of rotation designation D, as shown below. The OPTION designation S is for counter-clockwise output shaft rotation to produce gripper-arm motions in the opposite direction.

Fig. 3 Direction of rotation

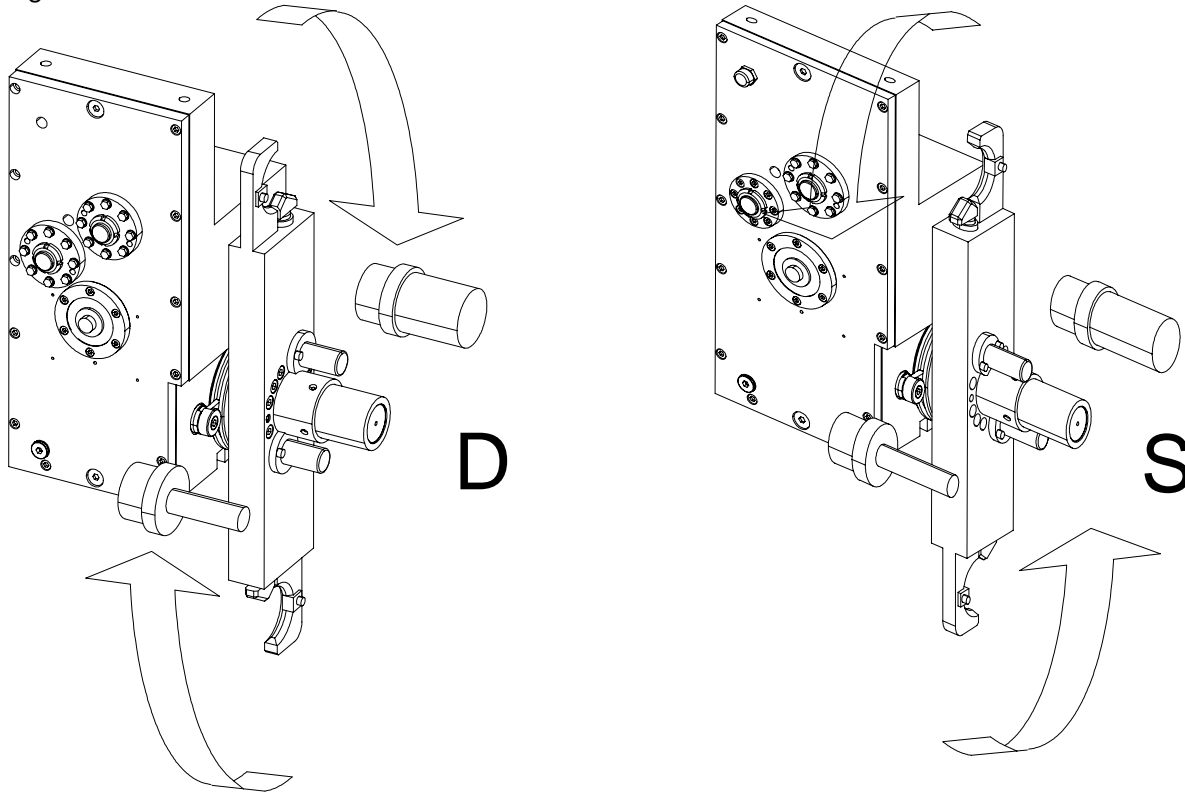

5. Danger area

Since we are dealing with a repetitive movement mechanism and positive coupling, the gripper arm moves only within its action range. The tool changer mechanism can be stopped only after: overload of the drive motor, reaction of the torque limiting coupling, failure of an internal component or power outage. Personnel must not be allowed to enter this danger area during operation.

During maintenance operations the power supply must be turned off prior to entering the danger area.

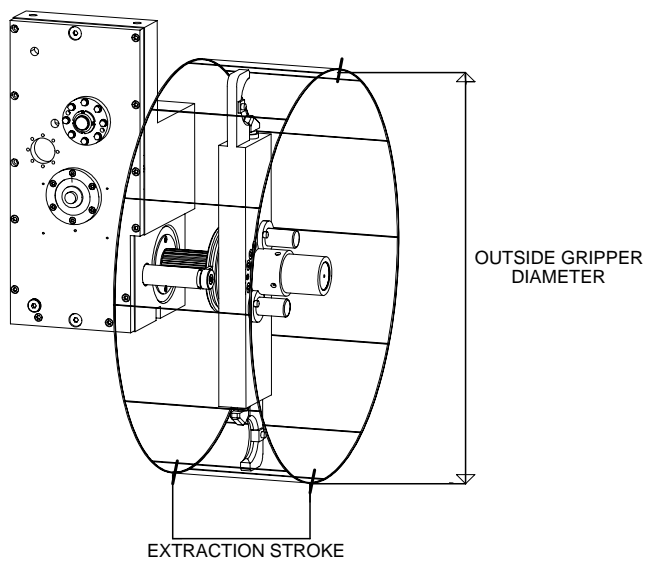

Fig. 4 Danger area

HTC140•HTC40•HTC50

6. Examples of applications

HTC tool-changers can be used for machine tools with horizontal-axis spindle. Rotation of the grippers to hold the tools (first rotation in the cycle) is clockwise in standard arrangements, but counter-clockwise rotation is available on request. In this case also the grippers must be specified for the counter-clockwise direction of rotation. Note: reversing the direction of rotation of the motor means performing the cycle in reverse order, but does not mean actuating gripping in a counter-clockwise direction.

7. System components

The extraction tool system is constructed by the following components:

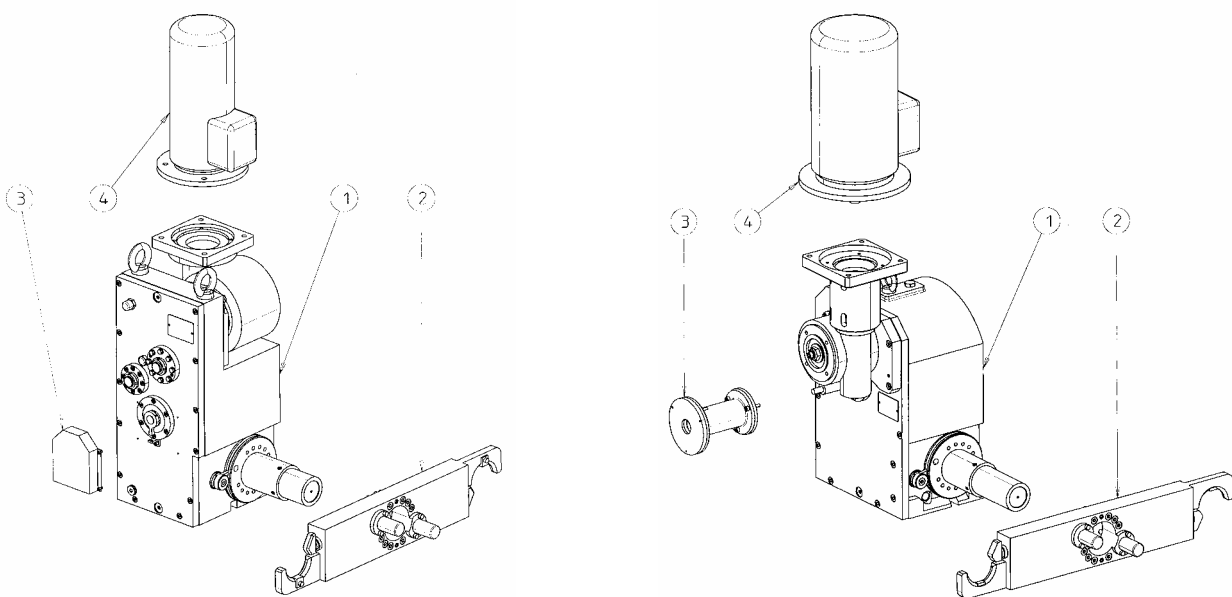

1	HTC TOOL CHANGER (HTC 40 – HTC 140 – HTC 50)
2	BPH EXCHANGE ARM (BPH 41 – BPH 51)
3	MOTION CONTROL ACCESSORIES (MICRO-ENCODER)
4	MOTOR

8. Sizing and Selection

The size of the HTC depends on the tool taper used in the machine tool to which it will be mounted, by the maximum weight of the tools to be transported, by toolholders and by the speed you want to realise. For correct functioning do not exceed the values of size, load, and speed shown in the table 2. Together, these tabulated values determine the maximum torque and force available for this application.

If any of these values are exceeded, please contact our Engineering department to have your application evaluated.

HTC140•HTC40•HTC50

9. Using a self-braking motor

A self-braking motor is used to stop the mechanism during a dwell provided at the end of each tool change cycle. It will remain there until the machine control calls for another tool change cycle.

To facilitate adjustment and synchronization during installation or for maintenance manual brake release to allow manual drive shaft rotation, is provided.

An alternative to self-braking motors, is inverter or vector controlled. These have been used successfully. These motors have no mechanical parts to wear, and allow precise regulation of speed. Another type of motor is the servomotor, position and speed controlled by an encoder.

10. Clutch torque limiter

The HTC standard motorization includes a worm reducer with a built-in externally adjustable torque limiter, the purpose of which is to eliminate the overload impact caused by inertia of the masses undergoing intermittent motion and therefore to prevent breakage of the mechanical components – both during mid-cycle stops and cycle restart after a mid-cycle stop.

11. Versions

The tool changers are available in the following versions:

VLRP = HTC complete with speed reducer and torque limiter which is prepared for attaching motor.

VLRA = HTC complete with self-braking gearmotor and torque limiter

VLRP

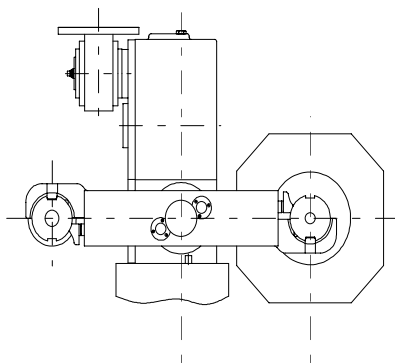

VLRA

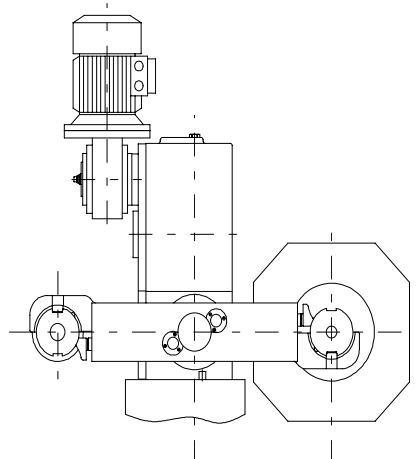

Fig. 6 - Versions

HTC140•HTC40•HTC50

1.2. Mounting positions of the reduction gear

HTC tool changers can be delivered complete with a self-braking gearmotor or simply with a worm gear reducer mounted in one position in respect to the HTC.

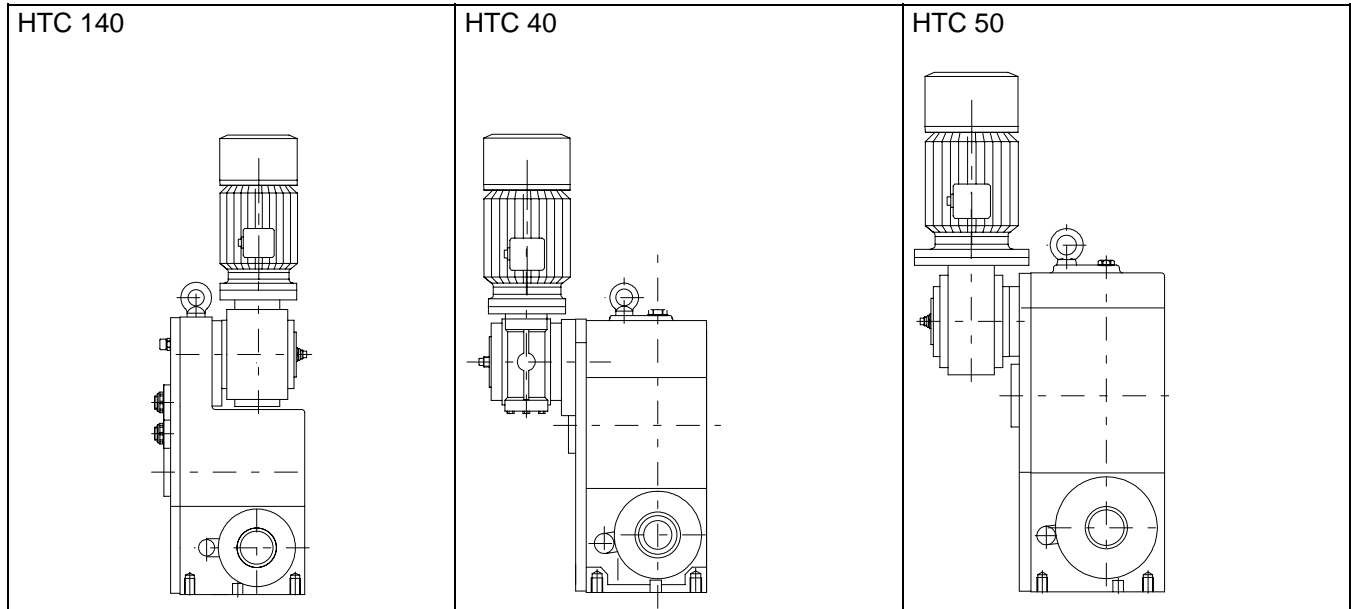

Fig. 7 Position of the reducer

HTC assemblies can be prepared for alternative systems other than standard applications, for example combinations of: coupling, clutch brake, speed variators, etc. Upon request, these can also be supplied directly by COLOMBO FILIPPETTI.

1.3. Technical characteristics

Tab.: 2

	HTC140	HTC40	HTC50
Max tool weight (kg)	10	15	25
Max stroke extraction (mm)	60	110	165
Exchange centers distance	Gripper arm 470	Gripper 520	Gripper 640
3 (kg)	1.2 (s)	1.7 (s)	-
5 (kg)	1.5 (s)	2.1 (s)	-
8 (kg)	1.9 (s)	2.6 (s)	2.3 (s)
10 (kg)	2.0 (s)	2.9 (s)	2.5 (s)
15 (kg)	-	3.5 (s)	3 (s)
20 (kg)	-	-	3.2 (s)
25 (kg)	-	-	3.5 (s)

N.B. The exchange time is influenced by the length of gripper arm and maximum tool weight. Please consult with our engineering department regarding your application requirements.

HTC140•HTC40•HTC50

1 4. Overall dimensions HTC 1 40

Fig. 8 - HTC 140 Version VRP

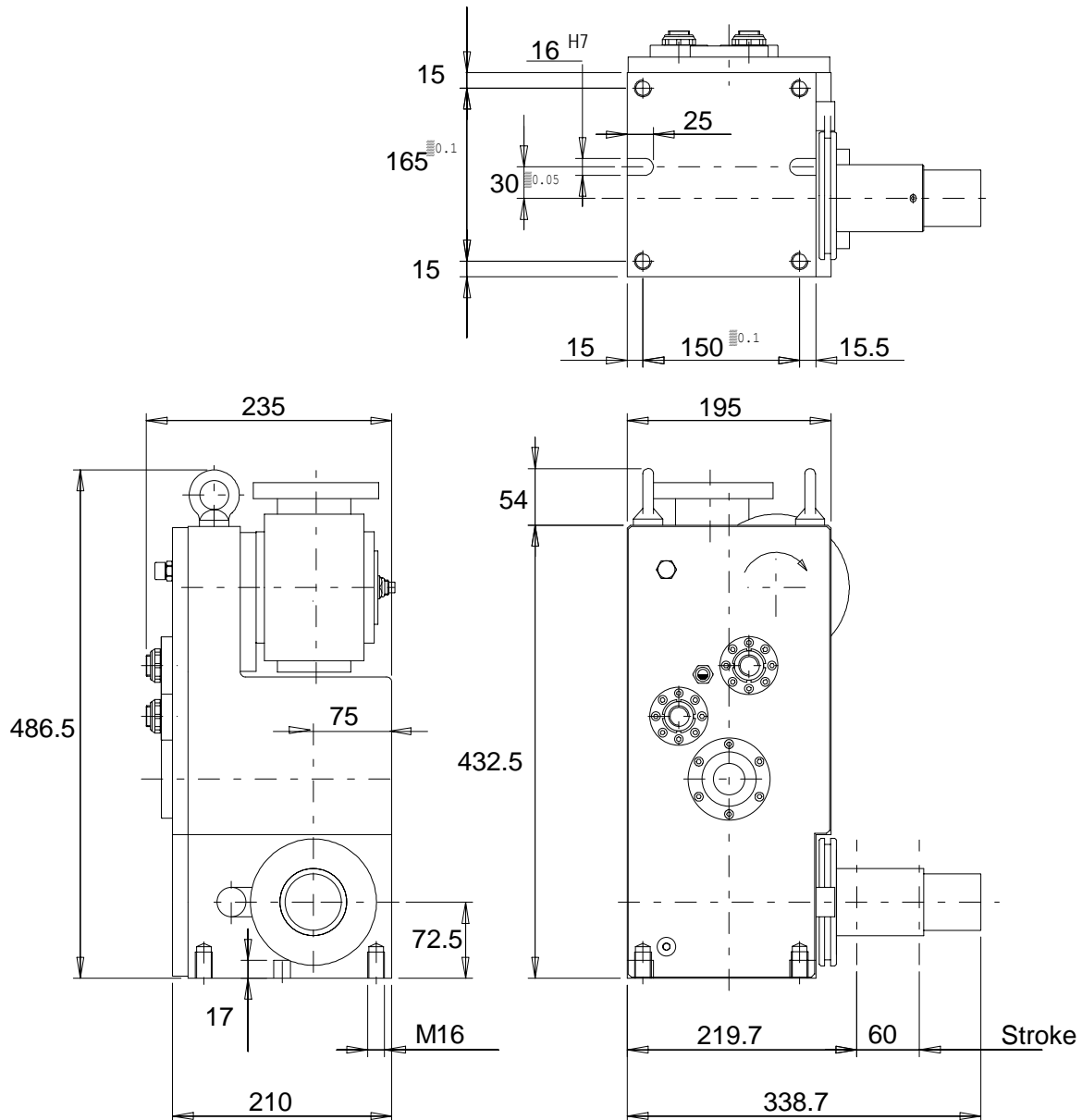

- Linear tool extraction and insertion stroke of tools is 60 (mm) is the longest achievable; upon request, tool changers with shorter stroke can be supplied.
- Mounting of the assembly is achieved by tapped holes in housing, two dowel pins can be added to maintain precise final position, after having checked that the machine spindle axis and the HTC 140 output shaft are parallel.
- Standard motorization is (hollow shaft mounted directly on the input shaft of the worm gear reducer) by a self-braking electric motor, size depending on power required.
- Machine cycle must be controlled by a set of 3 micro switches placed on the external side of the reducer. Dimensions of micro switches are in paragraph 16.

HTC140•HTC40•HTC50

Fig. 9 HTC 40 Version VLRA

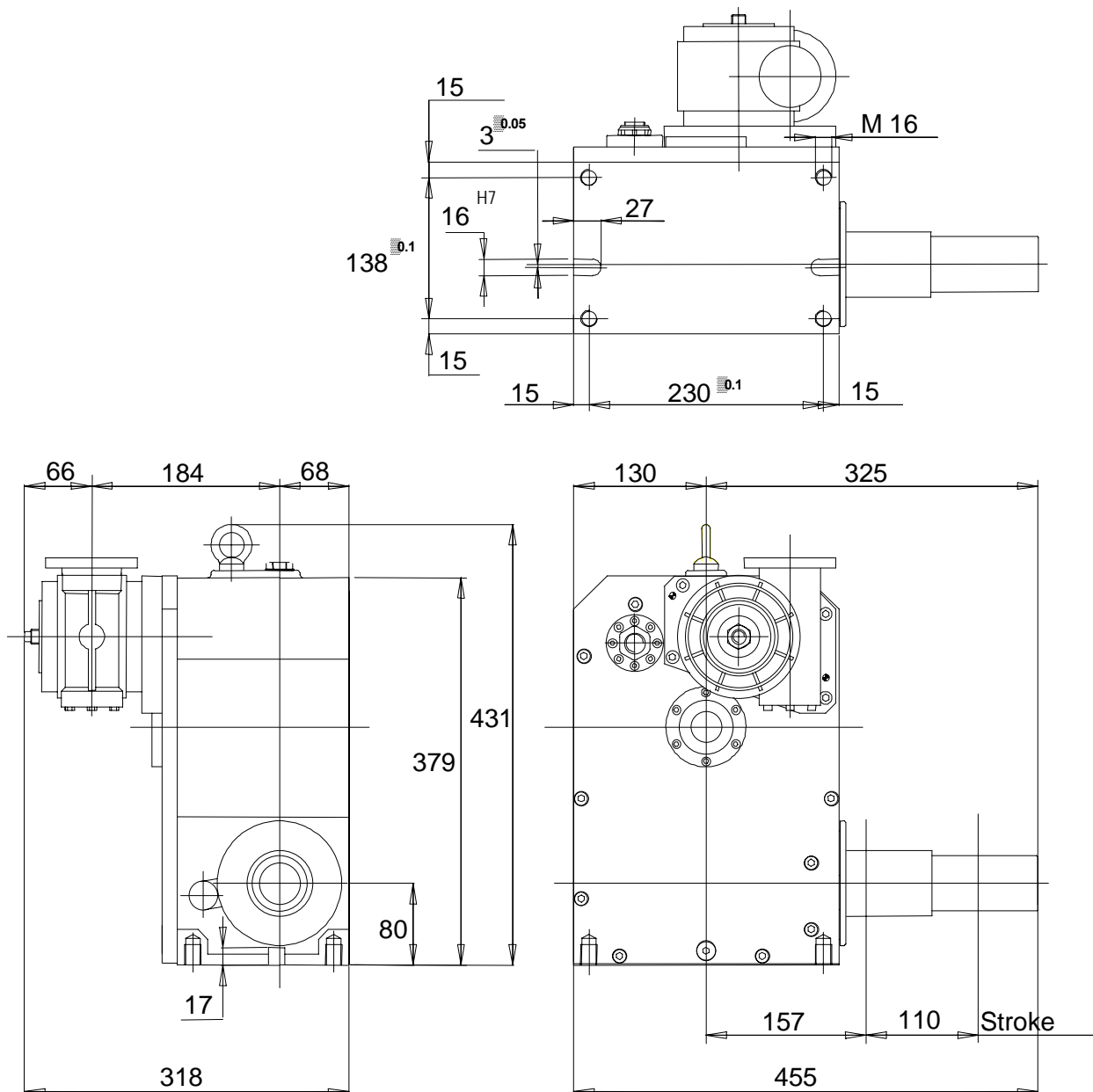

- Linear tool extraction and insertion stroke of tools is 110 (mm) is the longest achievable; upon request, tool changers with shorter stroke can be supplied.
- Mounting of the assembly is achieved by tapped holes in housing, two dowel pins can be added to maintain precise final position, after having checked that the machine spindle axis and the HTC 40 output shaft are parallel.
- Standard motorization is (hollow shaft mounted directly on the input shaft of the worm gear reducer) by a self-braking electric motor, size depending on power required.
- Machine cycle must be controlled by a set of 3 micro switches placed on the external side of the reducer. Dimensions of micro switches are in paragraph 16.

HTC140•HTC40•HTC50

Fig. 10 HTC 50 Version VLRA

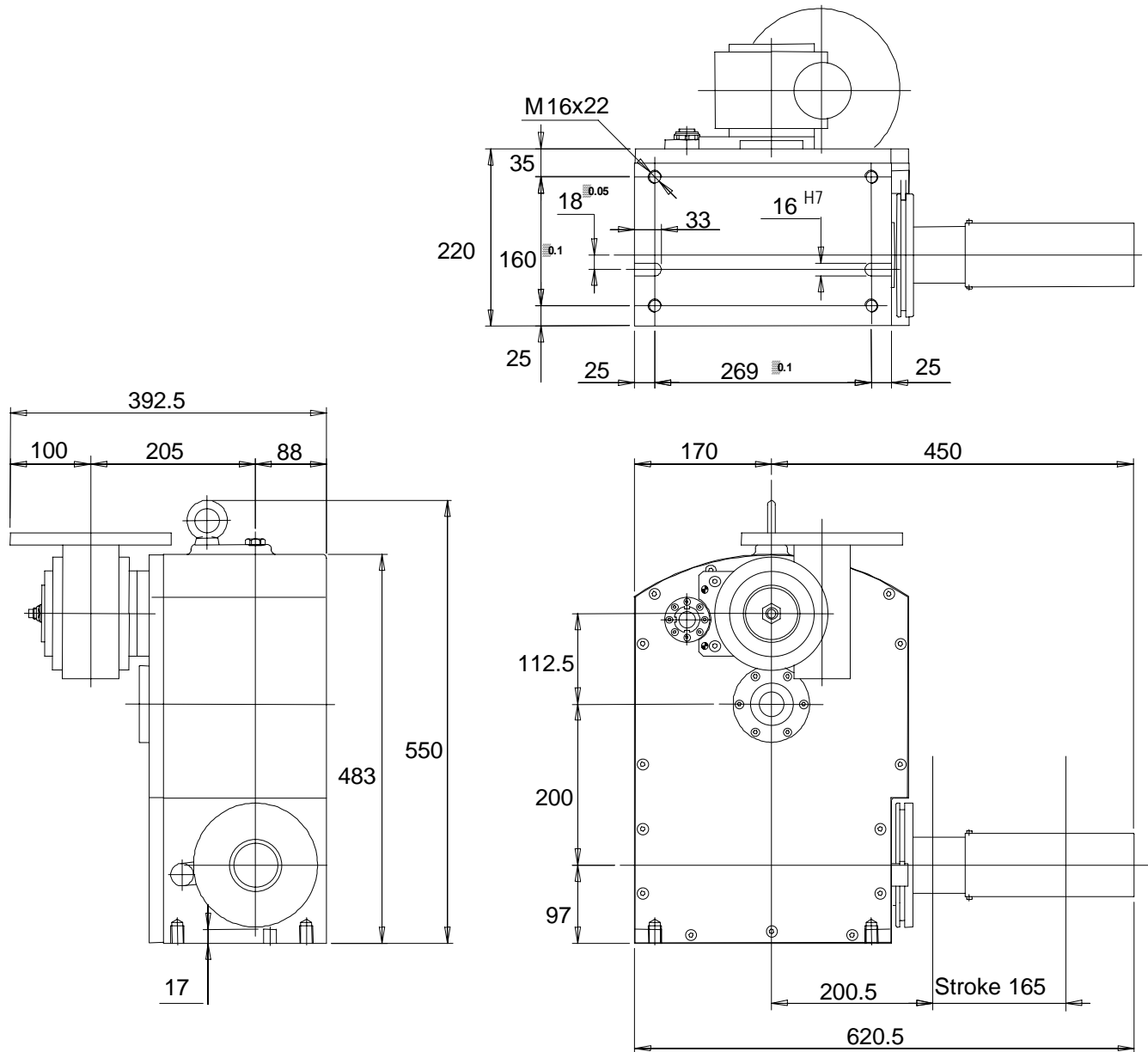

- Linear tool extraction and insertion stroke of tools is 165 (mm) is the longest achievable; upon request, tool changers with shorter stroke can be supplied.
- Mounting of the assembly is achieved by tapped holes in housing, two dowel pins can be added to maintain precise final position, after having checked that the machine spindle axis and the HTC 50 output shaft are parallel.
- Standard motorization is (hollow shaft mounted directly on the input shaft of the worm gear reducer) by a self-braking electric motor, size depending on power required.
- Machine cycle must be controlled by a set of 3 micro switches placed on the external side of the reducer. Dimensions of micro switches are in paragraph 16.

HTC140•HTC40•HTC50

15. Characteristics of output motion

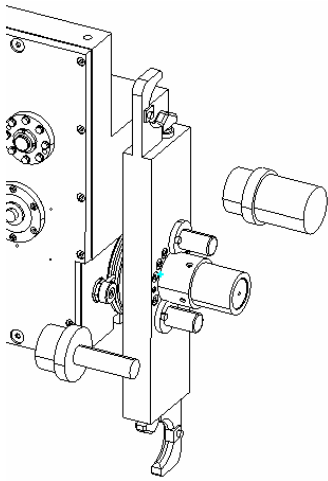

Fig. 11

PRECISION OF OUTPUT MOTION

- Rotation 180° ±0.05 [degrees]
- Linear stroke 110/60 ±0.20 [mm]
- Repeatability ± 0.03 [--]
- Coplanarity 0.05 [mm]
- Concentricity 0.05 [mm]

16. Mounting and use of limit switch cams

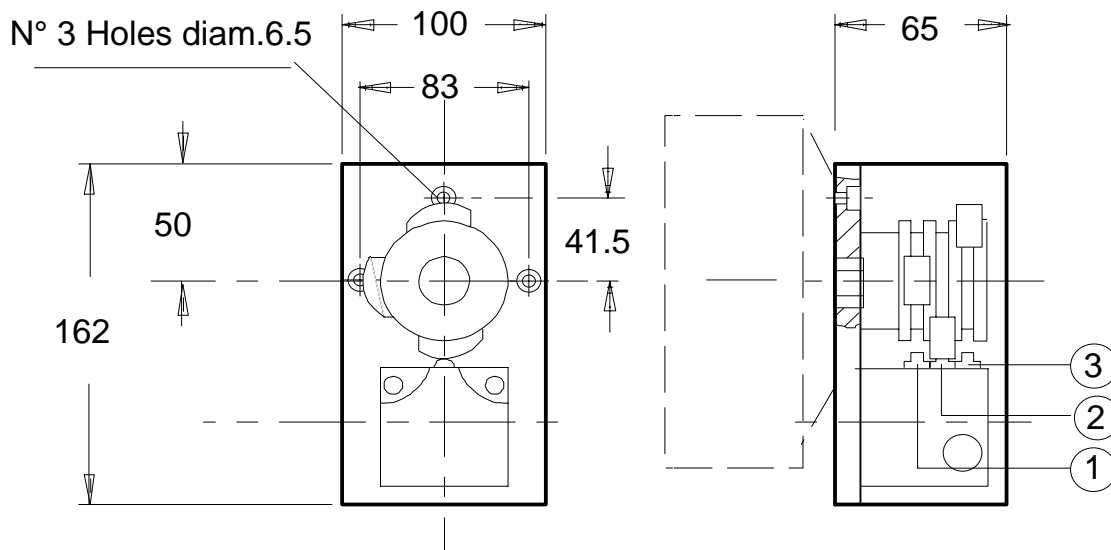

Fig. 12 - Overall dimensions of complete FC3 assembly
 Model and manufacturer of the multiple precision limit switch
 Balluff. BNS 543-B 03 R 12-61-12, or, EUCHNER SN 3-R 12-502

As already described in section 21 the cams are mounted in such way as to actuate the limit switches that comand:

- 1) The dwell of the HTC in position end of cycle
 - 2) The release of the gripper arm
 - 3) Clamping of the gripper arm after substitution
- Complete cycle is made at complete rotation of the cam shaft.

HTC140•HTC40•HTC50

17. Description of the gripper arm

The tool changer gripper arm consists of a central aluminium structure with terminal tool grippers of hardened steel.

Tool gripping and release are obtained by means of a spring-operated mechanism actuated by the rotation of the arm. The latter, in turning, engages or disengages the grippers from the tools when these are in exchange position. While in motion, an irreversible mechanical type safety interlocking device enters automatically into operation and prevents accidental opening of the tool gripper.

The gripper arm is attached to the HTC output shaft by means of a taper compression device which permits easy infinite adjustment and rigid final fixing.

The automatic locking mechanism inside the gripper arm is grease-lubricated and is practically maintenance-free. The initial positions of the different cycle stages are determined mechanically by the cam of the HTC, so after synchronisation and securing of the gripper on the shaft, the repeatability of the cycle and its positions are absolutely guaranteed.

18. Overall dimensions

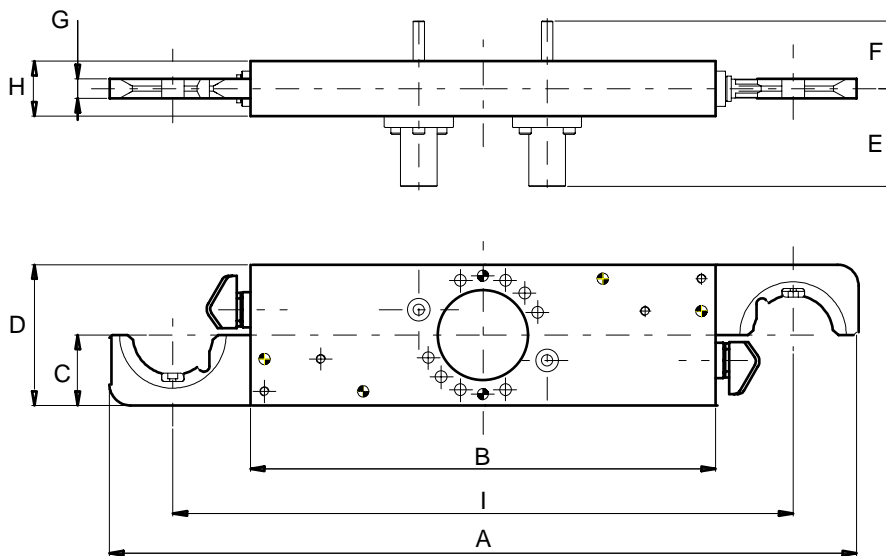

Fig. 13- Arm Gripper

Tab. 3

SERIES	Distance	A	B	C	D	E	F	G	H	Weight Kg
	I									
BPH 41	400	480	290							5.5
	450	530	340							6
	500	580	390	50	100	70	35	14	40	7
	550	630	440							7.5
	600	680	490							8.5
	650	730	540							9
BPH 51	500	630	330							9
	550	680	380							9.5
	600	730	430							10.5
	650	780	480	75	120	66	43.5	14	50	11.5
	700	830	530							12.3
	750	880	580							13
	800	930	630							14

HTC140•HTC40•HTC50

19. Type of tool taper

Tab. 4

code *	Type of taper	norm	Stroke extraction	Gripper arm type	Exchange type	
L1	ISO 40	DIN 69871	110	BPH 41	HTC 40	
L2	ISO 40B **		110			
L3						
M1	BT 40	JIS B 6339	110			
M2						
M3						
N1	HSK 50 A	DIN 69893	60		HTC 140	
N2	HSK 50 B	DIN 69893	60			
N3	HSK 50 E	DIN 69893	60			
P1	HSK 63 A	DIN 69893	60			
P2	HSK 63 E	DIN 69893	60			
P3	HSK 63 F	DIN 69893	60			

code *	Type of taper	norm	Stroke extraction	Gripper arm type	Exchange type	
R1	BT 50	JIS B 6339	165	BPH 51	HTC 50	
R2						
R3						
T1	HSK 80 A	DIN 69893	85			
T2	HSK 80 B	DIN 69893	85			
T3	HSK 80 F	DIN 69893	85			
U1	HSK 100A	DIN 69893	85			
U2	HSK 100B	DIN 69893	85			
U3	HSK 100F	DIN 69893	85			
V1	ISO 45	DIN 69871	165			
V2						
V3						

Grippers are available types of tapers other than those indicated on the chart, such tapers must be identified and the letter "S" will be used in the designation for type of gripper as code indicated for a special taper .



Special cones not indicated on the chart are identified by an "s" followed by the type of cone, example: "S" (capto C6)

*. Code to insert in designation

** (ANSI B5.50 – CAT 40)

*** (ANSI B5.50 – CAT 50)

HTC140•HTC40•HTC50

20. Designations of the HTC tool changer

The designation of the HTC assemblies consist of sets of alphanumerical characters as illustrated in the chart below. Please refer to this chart when ordering, to avoid misunderstandings and delays in deliveries.

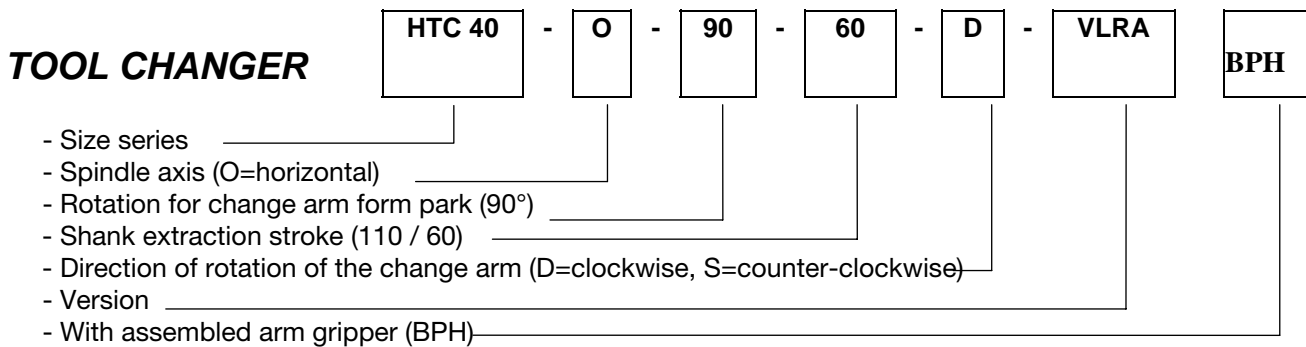

EXAMPLE OF DESIGNATION

HTC 40 tool changer for machine tool with BT 40 taper, horizontal spindle axis, tool arm rotation 90° clockwise from park, supplied with a self-braking gearmotor and torque limiter. With assembled arm gripper

HTC 40 - O - 90 - 60 - D - VLRA - BHP

When ordering, in addition to stating the position where the reduction gear is mounted, one must also specify all data required to identify the characteristics of the motors. Such data are:

- 1) The reduction ratio of the worm screw reduction gear and / or cycle time;
- 2) The size of the IEC B5 motor flange when the reducer is required without motor preset for keying.
- 3) The specifications of the electric motor: power, polarity, voltage, frequency, etc.
- 4) The FC3 limit switch assembly, if required

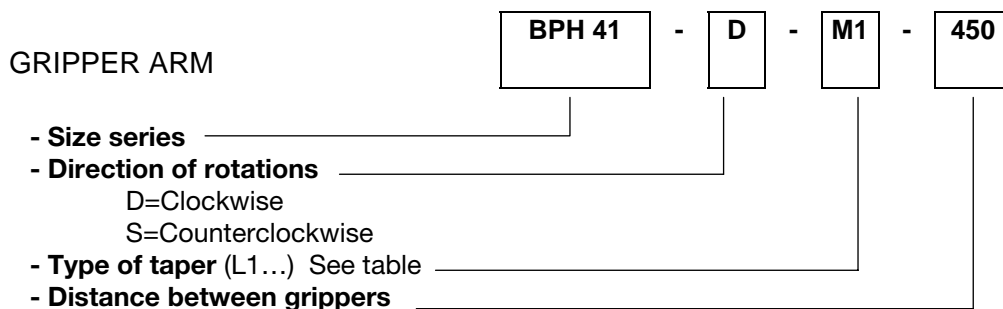

EXAMPLE: Gripper arm for BT 40 taper with gripper distance 450 [mm]

GRIPPER ARM BPH 41

HTC140•HTC40•HTC50

21. - Instructions for correct operation

The HTC Tool Changer is equipped with a limit switch group of 3 micro cams and a bank of 3 limit switch. These are used to control the stopping positions of the HTC Tool Changer and your draw bar release and clamp. The cams are infinitely adjustable in their tracks. The cams have been adjusted at the factory but may have to be readjusted after the tool changer has been installed on your machine.

FC1/A is the switch next to the HTC.

This switch should be adjusted so that the arm stops in the dwell of the park position.

FC1/B is the second one and is for the draw bar release.

This switch should be adjusted so that the arm stops in the short dwell where the grippers are fully located on the tools but the arm has not started the extraction stroke.

FC1/C is the third one and is for the dwell for activating draw bar clamp.

NOTE: HSK drawbars are available that pre-release the tool but still retain it in the spindle. When using these drawbars the tool change does not have to stop during the cycle to wait for drawbar release or clamp. Only FC1/A is required in this case.

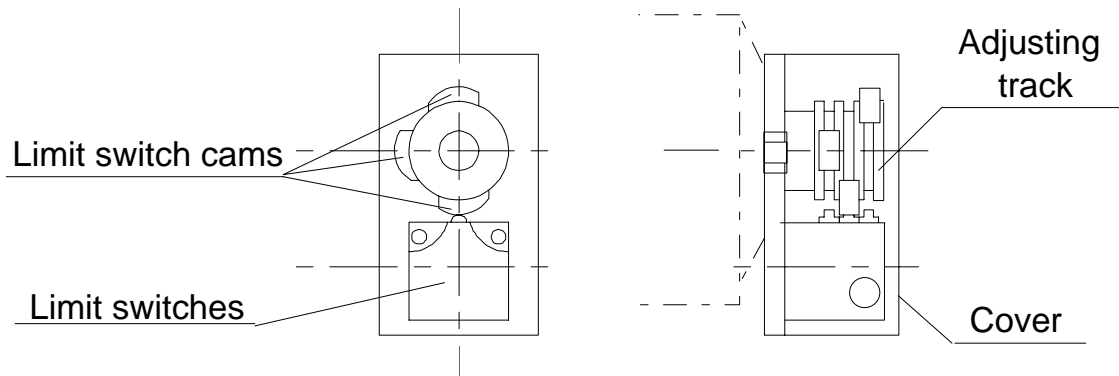

Fig. 14 micro cams FC3

22. - Setup operation

The HTC are supplied, unless specified otherwise, with long-life lubricant consisting of mineral lubricating oil ISO VG 150. The box is fitted with a filling hole and drain plug. A label is attached to each unit to show presence or lack of lubricant, a yellow label indicates presence of lubricant and a red label indicates lack of lubricant. Listed below are some other oil brands which correspond to ISO VG150:

Tab 1

ISO	VG 150	ESSO	Spartan EP 150
AGIP	Blasia 150	FINA	Giran 150
BP	Energol GR-XP 150	MOBIL	Mobilgear 629
CASTROL	Alpha SP 150	SHELL	Omala Oil 150
CHEVRON	NL Gear Compound 150	TOTAL	Carter EP 150

When adding oil, check that the oil is clean and that fine-mesh filter is used. To assure proper lubrication see Tab. 1

23. Maintenance

HTC mechanisms require very little maintenance. Check the box occasionally for oil leakage, as it is a sign of malfunctioning of the assembly or wear of the seals. If oil is noticed, proper maintenance should be carried out to eliminate the cause.

After 8,000 hours of operation, the HTC assembly gripper shaft should be checked for backlash.

Always ensure that there is unrestricted flow of clean dry air for motor cooling purposes.

Check brake for wear in accordance with motor manufacturer's instructions.