

CAM TOOL CHANGER

CUT31. CUT41. CUT51

CUT



- Smooth quiet motion
- Complete mechanical synchronization of cycle
- Both vertical and horizontal axis mounting position
- Positive control of acceleration and speed during full cycle
- Long life lubrication
- Motorised assembly complete
- Arm with tool grippers automatically locked during rotation
- Simple and compact construction
- Internal torque limiting device



COLOMBO FILIPPETTI SPA

COLLABORATIVE ENGINEERING

CF1711 09-04

Via Rossini, 26 I-24040 CASIRATE D'ADDA -BG -Tel 0363-3251 Fax 0363-325252
<http://www.cofil.it> - E-mail cofil@cofil.it



Collaborative Engineering

Contents

PAG

1.	General.....	2
2.	Sequence of cycle motions.....	2
3.	Directions of rotation of the gripper arm	2
4.	Danger area	3
5.	Examples of applications	3
6.	Choice of type.....	3
7.	Mounting instructions	3
8.	Using the self-braking motor	3
9.	Clutch torque limiter.	4
10.	Instructions for correct operation.....	4
11.	Preparation.	4
12.	Maintenance.....	5
13.	Versions	5
14.	Designations of the CUT tool changers.....	5
15.	Mounting positions of the reduction gear.....	6
16.	Technical characteristics	6
17.	Overall dimensions CUT 31	7
18.	Overall dimensions CUT 41	9
19.	Overall dimensions CUT 51	11
20.	Technical characteristics of the reduction gears	13
21.	Mounting and use of limit switch cams	13
22.	Description of the gripper arms.....	14
23.	Overall dimensions.....	14
24.	TYPE OF TOOL TAPER	15
25.	Designation of gripper arm BP	15
26.	Selection diagram.CUT31	16
27.	Selection diagram.CUT41	16
28.	Selection diagram.CUT51	17

The units of measurement correspond with System International /Severity Index SI General tolerances of manufacture are conform to UNI – ISO 2768-1 UNI EN 22768-1

Illustrations and drawings according to UNI 3970 (ISO 128-82).

Method of projection of the drawings.

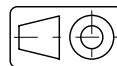

All rights reserved. No part of this catalogue may be duplicated.

COLOMBO FILIPPETTI may make any changes they feel necessary for the improvement of their products without advance notice.

COLOMBO FILIPPETTI may change any market components and accessories mentioned in this catalogue as they feel necessary.

This catalogue supersedes all earlier ones.

1- General

The CUT devices manufactured by COLOMBO FILIPPETTI are mechanical, machine-independent tool change assemblies which, by means of a cam drive, transform an incoming uniform rotary motion supplied by a gearmotor into a regular series of stop-and-go linear and rotary movements of the output shaft onto which the arm of the tool gripper is fixed. The synchronous combination of movements performed by the gripper arm provides the typical tool change cycle which is a characteristic feature of this device.

The design of the product is a simple one: its movements are transformed directly by a mechanical cam and feeler system which controls the acceleration of the intermittent motions and assures positive control throughout the cycle. The main features which are a result of this include accuracy, speed and smoothness of the movements, low vibration and silent operation, versatility in its applications and minimal overall dimensions.

2.- Sequence of cycle motions

The angle of rotation of the gripper for engaging and releasing the tool is 90° or, on demand, 60°. The tool exchange rotation is 180°. Standard extraction and insertion stroke varies as relevant taper (See Tab.1).

Fig. 1 - Sequence of the Tool Change cycle.

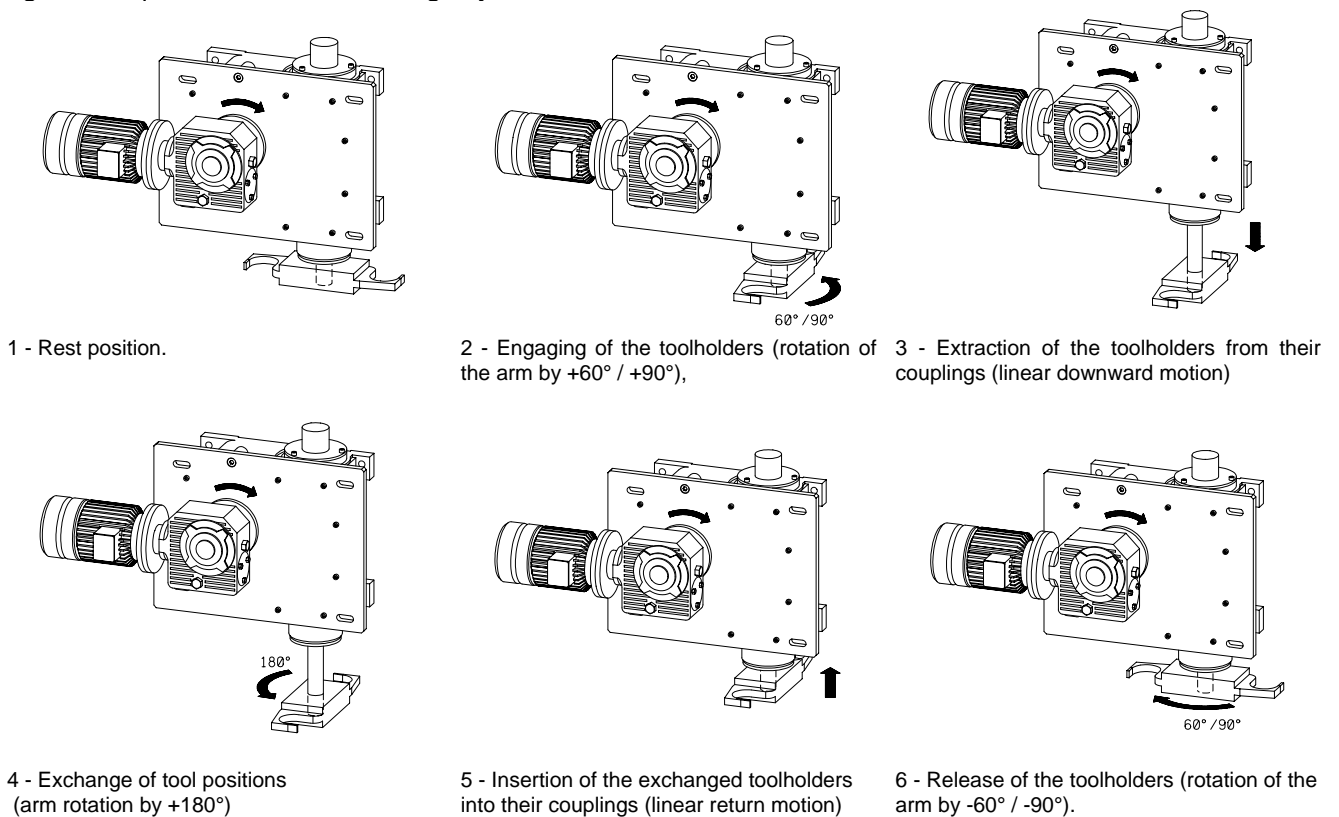

3.- Directions of rotation of the gripper arm.

The STANDARD senses of rotation (designation "D"), is as shown in figure 1 above, i.e. clockwise INPUT shaft motion as shown, produces gripper-arm motion as fig. 1 diagrams 1 through 6. The OPTION (designation "S") is for anti-clockwise input shaft motion (as before) to produce gripper-arm motion in the opposite sense.

Fig. 2 - Directions of rotation.



4.- Danger area

Since it is a positive-action arrangement, the gripper arm moves only within its range. Apart from switching-off, stoppage can occur only owing to an overload of the drive motor, to action by a torque limiter or to breakdown of some internal part.

It is therefore essential not to enter the range of action of the device while it is in operation. When carrying out maintenance, the power must be cut before access to the danger area.

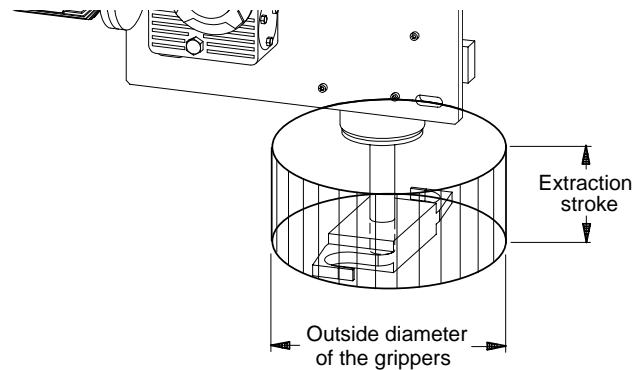

Fig. 3 - Danger area

5.- Examples of applications

CUT tool-changers can be used for machine tools with vertical-axis spindle as well as with horizontal-axis spindle. Rotation of the grippers to hold the tools (first rotation in the cycle) is clockwise in standard arrangements, but counter-clockwise rotation is available on demand. In this case also the grippers must be suitable for the counter-clockwise direction of rotation. Note: reversing the direction of rotation of the motor means performing the cycle in reverse order, but does not mean actuating gripping in a counter-clockwise direction.

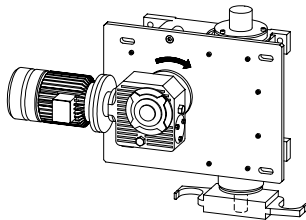

Fig. 4 - Vertical machine spindle axis

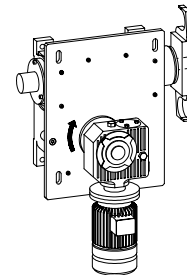

Fig. 5 - Horizontal machine spindle axis

6.- Choice of type.

The size of the CUT depends on the tool taper to be used.

For correct operation one must not exceed the value of size; load; speed shown in the data sheet. Together, these tabulated values determine the maximum torque and force available for the relevant CUT.

If any of these values is exceeded, contact should be taken with our Engineering department to have the device inspected.

7.- Mounting instructions.

The CUT assemblies can be mounted in any orientation, but fill; drain; vent plugs must be repositioned as necessary.

The main plate of the CUT is used with screws to achieve approximate mounting position on the machine. Final accurate position is normally achieved with dowel pins.

8.- Using the self-braking motor.

The self-braking motor is used to stop the mechanism during the mechanical pause (cam dwell period), provided at the end of each tool change cycle, where it will remain until machine control calls for another tool change cycle.

To facilitate adjustment and synchronisation on first mount or maintenance, use of manual brake release and manual drive shaft rotation will be helpful.

9.- Clutch torque limiter.

The CUT assembly standard motor includes worm reduction gear with built-in, externally adjustable, torque limiter, the purpose of which is to eliminate - both during emergency stops and during cycle restart after the emergency - the overload impact caused by inertia of the masses undergoing intermittent motion and therefore to prevent breakage of the mechanical driving parts.

10.- Instructions for correct operation.

Standard CUT assemblies are fitted with an FC3 limit switch-operated detecting unit, a system consisting of 3 limit switches and 3 microcams which control the operations which the machine tool is to carry out during execution of a tool change cycle:

- The adjustment of the microcam which controls motor stopping must be such that the main camshaft stops half-way through the mechanical pause of the CUT assembly.
- The adjustment of the microcam which enables tool release must be such that it occurs at the same time as the interchange arm engages the tools and therefore before extraction starts.
- The adjustment of the microcam which enables tool clamping must be such that it occurs at the same time as the interchange arm has completed insertion of the new tools, but before it releases them.

In order to facilitate these operations, the mechanical cycle of the interchange arm motion includes some brief pauses.

It is also necessary to avoid motor stoppage during motion as it might cause serious damage to the assembly. If a jogging motion is required during synchronising, this must be planned ahead when selecting the machine configuration, for example by allowing such operations to take place only at low speed. It is best to make provision for manual execution of these operations by turning the drive shaft by hand.

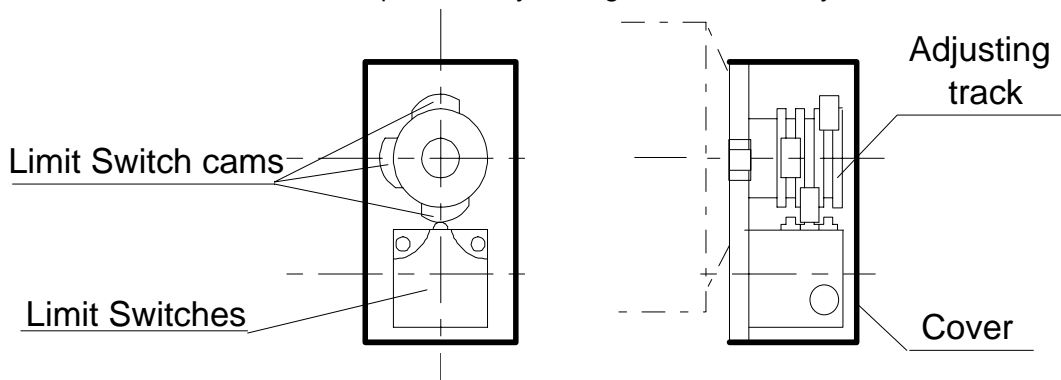

Fig. 6 - FC3 unit.

11.- Preparation

Unless specified otherwise, we supply the CUT devices already filled with long-life lubricant consisting of mineral lubricating oil ISO VG-150. The box is fitted with 2 holes for filling and draining the lubricant. A label is glued to each box to show presence or lack of lubricant. Below some other mineral oil brands which correspond to ISO VG150:

AGIP	Blasia 150
BP	Energol GR-XP 150
CASTROL	Alpha SP 150
CHEVRON	NL Gear Compound 150
ESSO	Spartan EP 150
FINA	Giran 150
MOBIL	Mobilgear 629
SHELL	Omala Oil 150
TOTAL	Carter EP 150

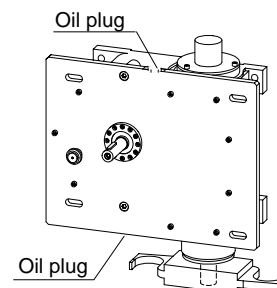

Fig. 7 - Position of the oil holes

When topping up, check that the oil is clean. A fine-mesh filter should be used to pour in the oil. See table 1 for the right amount of oil required for proper lubrication.

12.- Maintenance

CUT assemblies require very little maintenance. Check the box regularly for oil leakage, always a sign of malfunctioning of the assembly or wear of the seals. If any is noticed, proper maintenance should identify and eliminate the cause.

When carrying out routine servicing, and in any case after 8'000 hours of operation, the CUT assembly gripper shaft should be checked for backlash; if necessary, the whole assembly should be overhauled.

Always ensure that there is unrestricted free airflow for motor cooling purposes, and that such air cannot be contaminated with oil and hence affect the brake.

Check brake wear in accordance with motor manufacturer's instructions.

13.- Versions

The tool changers come in the following versions:

- VS** CUT with directly driven input shaft (camshaft).
- VL** CUT with long input shaft for mounting of standard speed reducer.
- VLR** CUT complete with bare shaft input speed reducer and torque limiter.
- VLRP** CUT complete with speed reducer (and torque limiter) which is prepared for mounting motor.
- VLRA** CUT with self-braking gearmotor and torque limiter

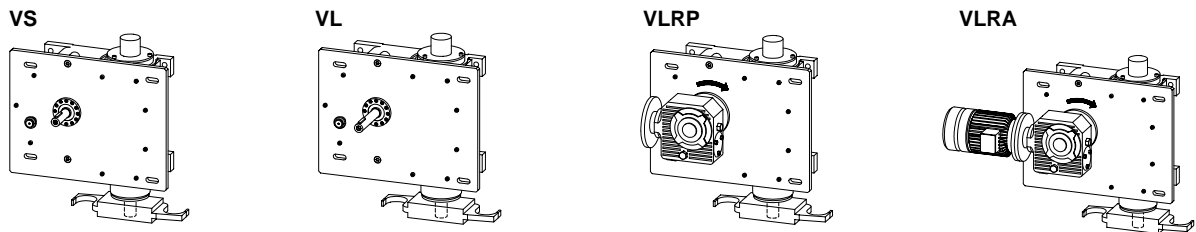
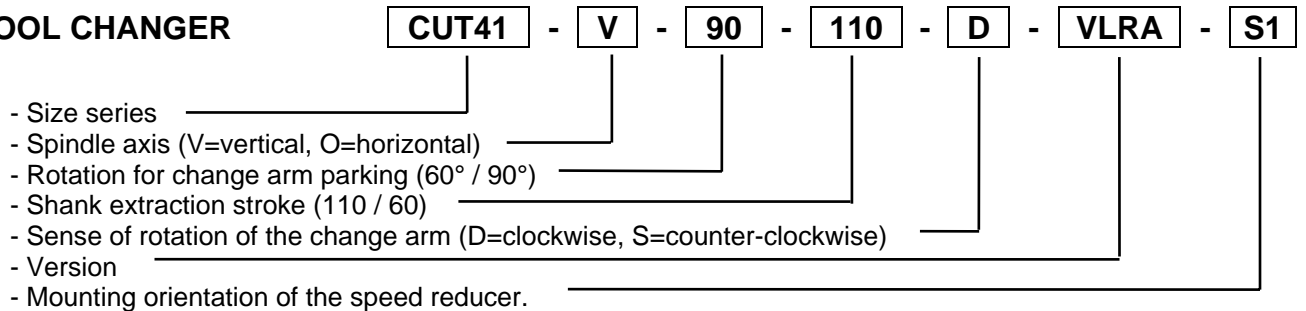

Fig. 8 - Versions

14.- Designations of the CUT tool changers.

The designation of the CUT assemblies consists of sets of alphanumeric characters as in the chart below. Please refer to this chart when ordering, to avoid misunderstandings and delays in deliveries.

TOOL CHANGER



EXAMPLE OF DESIGNATION

Of a CUT 41 tool changer for machine tool with SK 40 taper, vertical spindle axis, tool gripping rotation 90° clockwise, with self-braking gearmotor and torque limiter:

CUT41 - V - 90 - 110 - D - VLRA - S1

When ordering, in addition to the position where the reduction gear is mounted, one must also specify all data required to identify the characteristics of the motors. Such data are:

- 1) The reduction ratio of the worm screw reduction gear and/or cycle time;
- 2) For VLRP; the size of the IEC B5 motor flange.
- 3) The specifications of the electric motor: power, polarity, voltage, frequency, etc.
- 4) The FC3 limit switch assembly, if required.

15.- Mounting positions of the reduction gear.

CUT tool changers can be fitted with a self-braking gearmotor or simply with a worm screw reduction gear. They can be mounted in 6 different positions on the CUT assembly.

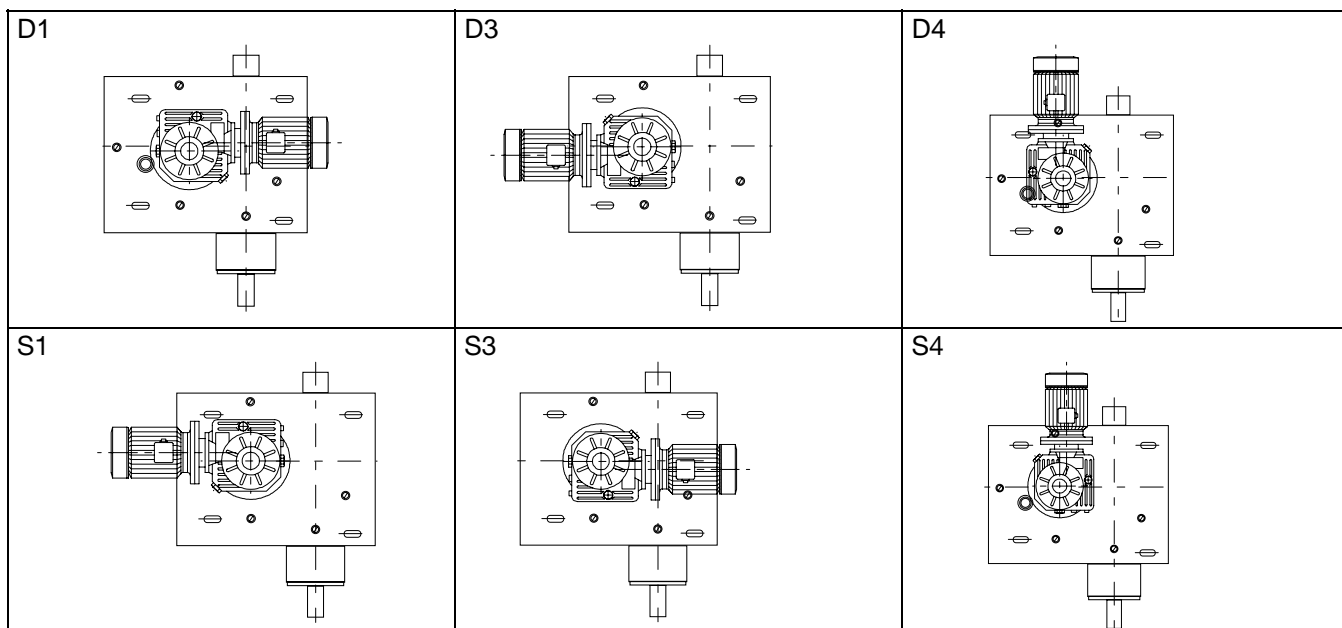

Fig. 9 - Positions of the reduction gear

Since the CUT assemblies may be provided with other drive systems than the standard ones, such as combinations of clutch-brake couplings, speed change gears, etc., all dimensional and technical features of these devices must be specified. On demand, these can also be supplied directly by COLOMBO FILIPPETTI.

16.- Technical characteristics.

Tab. 1

Series	Linear stroke (mm)	Max change arm centres (mm)	Max. tool weight (kg)	Max. stat. torque Ms (N.m)	Max. axial force Fa (N)	Time of cycle (s)	Installed Power (kW)	Lubr. (dm ³)	Mass (kg)
CUT 31	85 60	600	5	105	600	See selection diagrams	0.18	4.5	38
CUT 41	110 60	700	10	215	1400		0.37	7.2	65
CUT 51	165 85	800	20	415	2100		0.75	13	130

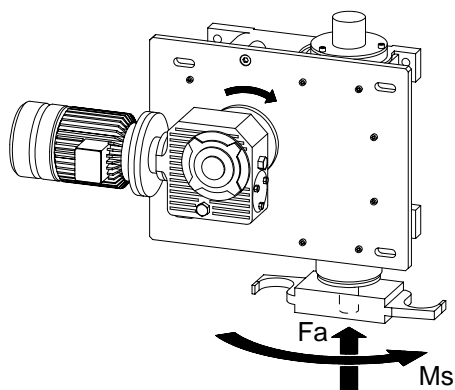

Fig. 10

ACCURACY OF OUTPUT MOVEMENTS

- Rotation 180° ± 0.05 [deg]
- Linear stroke 110/60 ± 0.20 [mm]
- Repeatability ± 0.03 [--]
- Coplanarity 0.05 [mm]
- Concentricity 0.05 [mm]

18.- Overall dimensions CUT 41

Fig. 13 - VS Version

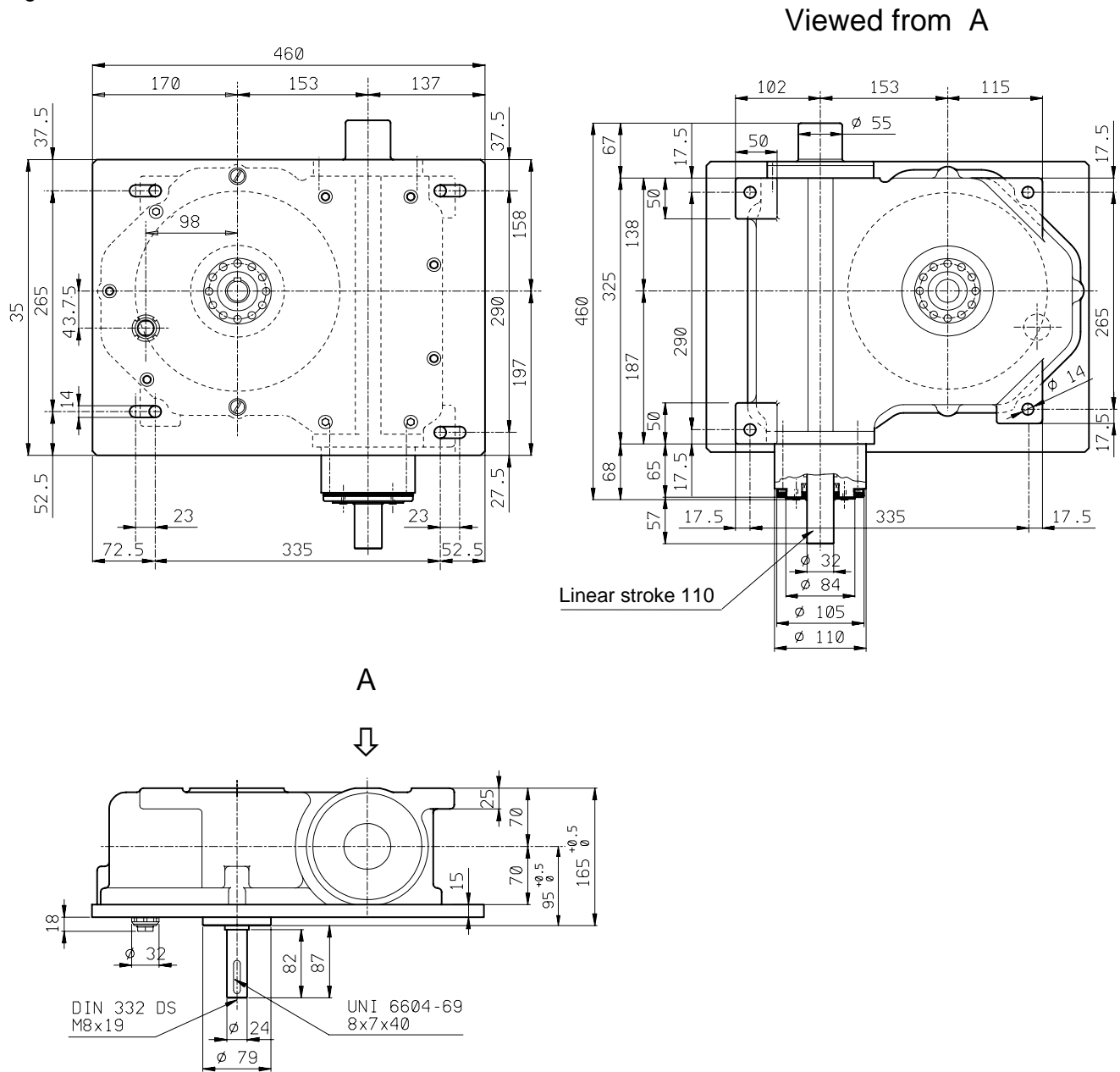

- The linear 110-mm tool extraction and insertion stroke is the longest achievable; on demand, tool changers with a shorter stroke can be supplied.
- Mounting of the assembly is achieved by the use of the 4 slots in the standard plate, plus two pins added to locate precise final position after having checked that the machine spindle axis and the CUT 41 output shaft are parallel.
- Cycle operation must be assisted by a set of at least 3 limit switches which receive the signals from limit switch cams attached to the CUT input shaft.

Fig. 14 - VLRA Version

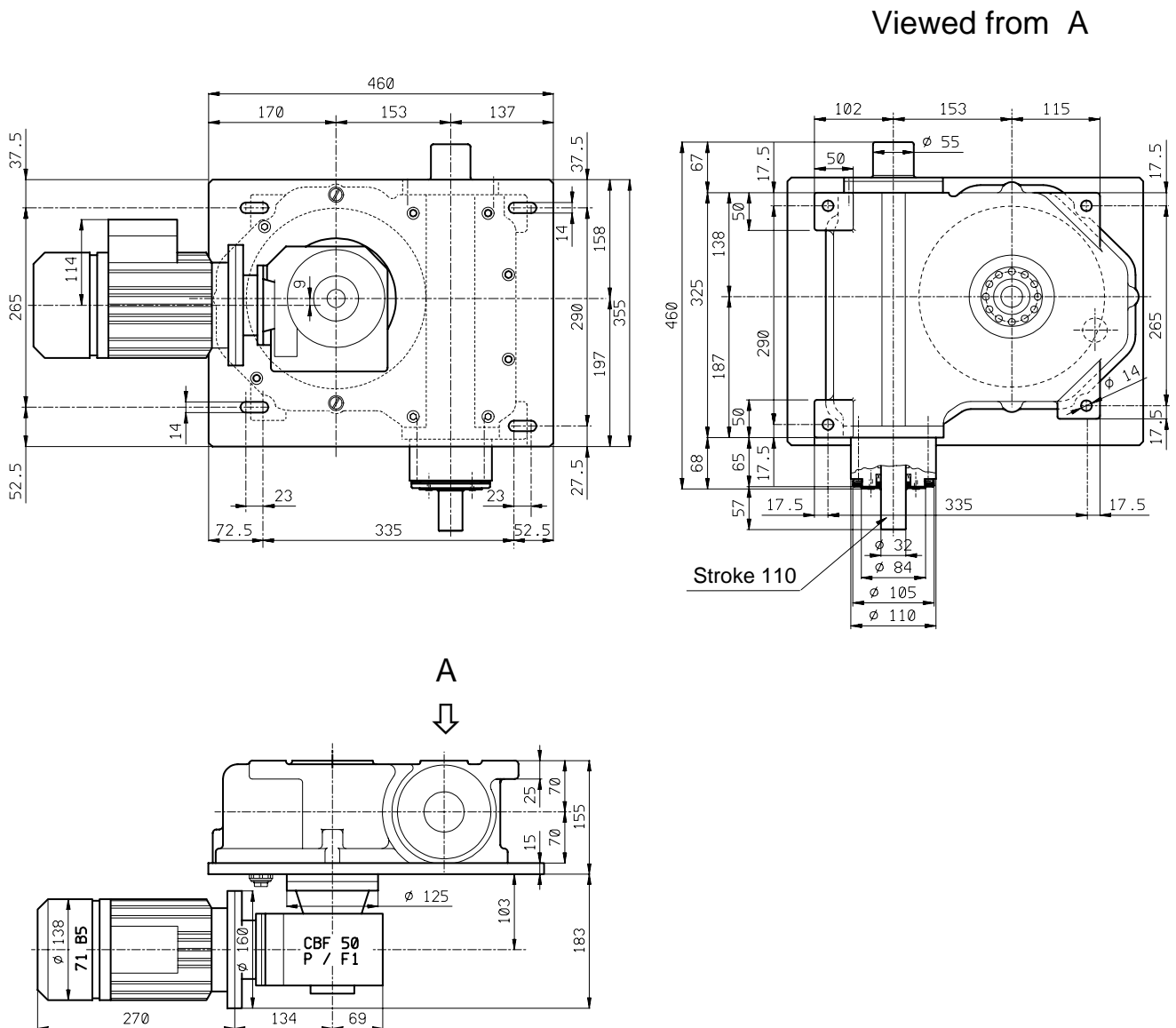

- The linear 110-mm tool extraction and insertion stroke is the longest achievable; on demand, tool changers with a shorter stroke can be supplied.
- Mounting of the assembly is achieved by the use of the 4 slots in the standard plate, plus two pins added to locate precise final position after having checked that the machine spindle axis and the CUT 41 output shaft are parallel.
- As standard, self brake electric worm geared motors are flange mounted directly on the input shaft.
- Machine cycle operation is controlled by a set of 3 limit switches on the external side of the reduction gear. The dimensions of the set of limit switches are specified under heading 21.

20.- Technical characteristics of the reduction gears

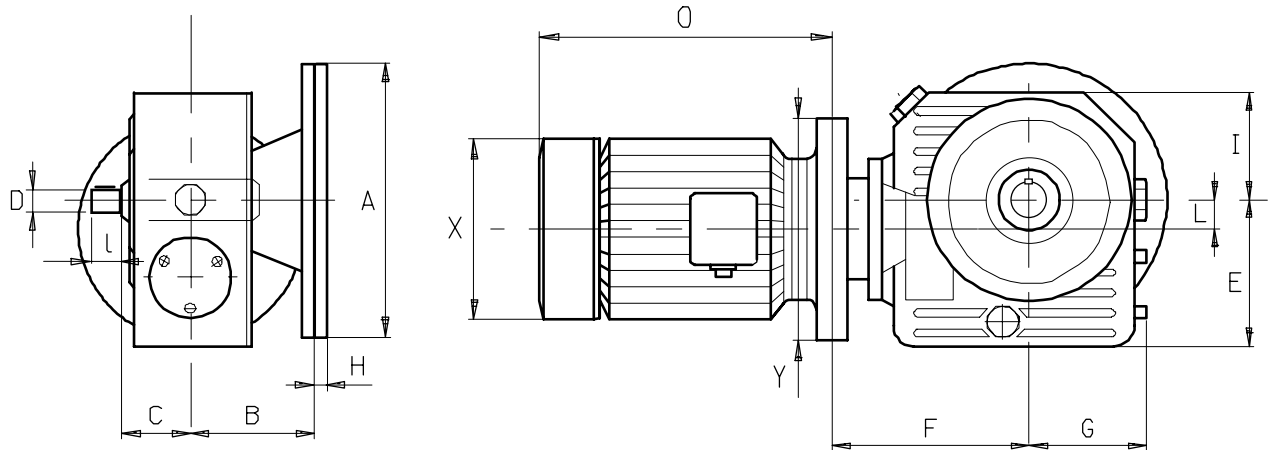

Fig.17 - STM CBF worm screw flanged reduction gear with preset torque limiter.

Tab. 2

Worm gear reducer STM. CBF LCB. Flange type F1/P Dimensions											Electric Motor Self braking - 4p-V 230/400-Hz 50				
Series	A	B	C	DxI	E	F	G	H	I	L	IEC	kW	O	X	Y
CBF40	106	69	49	9x30	78	108	59	10	57	7	63b	0.18	235	123	140
CBF50	125	93	60	9x30	97	134	69	10	69	9	71b	0.55	270	138	160
CBF70	175	116	66	9x30	127	165	93	10	88	17.5	80c	0.95	295	156	200

21.- Mounting and use of limit switch cams.

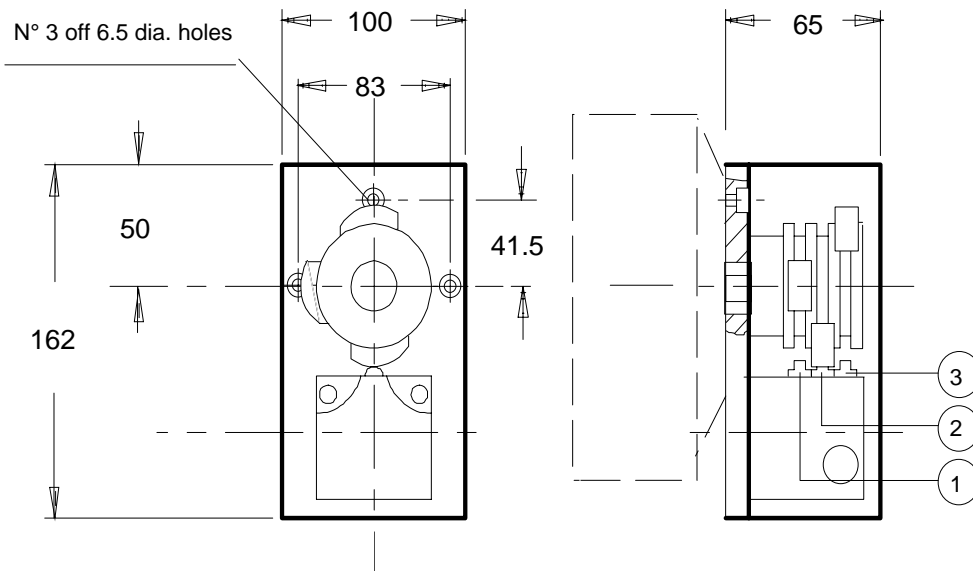

Fig. 18 - Overall dimensions of the complete FC3 assembly

Code of the multiple precision limit switch

Balluff BNS 543-B 03 k 12-61-12, or Euchner SN 3-R 12-502

As already described in paragraph 11, the cams are mounted in such a way as to actuate the limit switches. Depending on the cycle stage, they control:

- 1) The release of the tool spindle
- 2) The clamping of the tool spindle after exchange
- 3) Stopping of the CUT 41 at end of cycle position

The full cycle is executed with one complete revolution of the camshaft (input shaft) of the CUT.

22.- Description of the gripper arm.

The tool changer gripper arm consists of a central aluminium structure with terminal tool grippers of hardened steel.

Tool gripping and release are obtained by means of a spring-operated mechanism actuated by the rotation of the arm. The latter, in turning, engages or disengages the grippers from the tools when these are in exchange position. While in motion, an irreversible mechanical type safety interlocking device enters automatically into operation and prevents accidental opening of the tool gripper.

The gripper arm is attached to the CUT output shaft by means of a taper compression device which permits easy infinite adjustment and rigid final fixing.

The automatic locking mechanism inside the gripper arm is grease-lubricated and is practically maintenance-free.

The initial positions of the different cycle stages are determined mechanically by the cam of the CUT, so after synchronisation and securing of the gripper on the shaft, the repeatability of the cycle and its positions are absolutely guaranteed.

23.- Overall dimensions

Fig. 19 - Gripper arm overall dimensions.

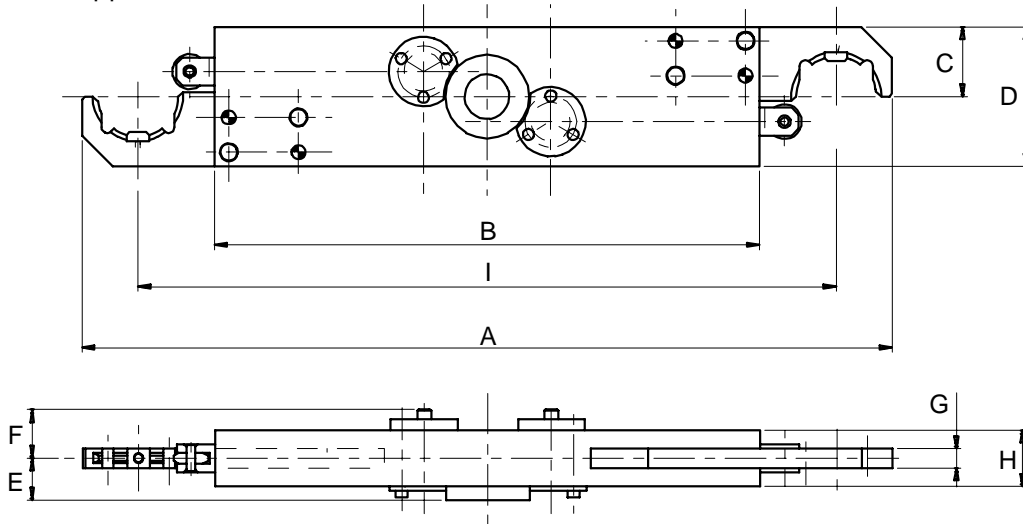

Tab. 3

SERIES	I	A	B	C	D	E	F	G	H
BP 30	350	422	250						
	400	472	300						
	450	522	350	40	80	33	36	14	40
	500	572	400						
	550	622	450						
	600	672	500						
BP 40	400	480	290						
	450	530	340						
	500	580	390	50	100	33	35	14	40
	550	630	440						
	600	680	490						
BP 50	650	730	540						
	500	630	330						
	550	680	380						
	600	730	430						
	650	780	480	75	120	33	43.5	14	50
	700	830	530						
	750	880	580						
800	930	630							

24 - Type of tool taper

Tab. 4

Type of tool taper	Reference details			Tool changer	Magazine
A	DIN 69871/69872	SK 40	ISO 40	CUT 41	CTM 40
B	JIS B6339	SK 40	(BT 40)		
C	DIN 69893	HSK - A 50			
D	DIN 69893	HSK - A 63			
E	DIN 69893	HSK - A 80			
F	DIN 69893	HSK - B 50			
G	DIN 69893	HSK - B 63			
H	DIN 69893	HSK - B 80			
J	DIN 69871/69872	SK 30	ISO 30	CUT 31	CTM 30
I	DIN 69893	HSK - A 32			
N	DIN 69893	HSK - A 40			
T	DIN 69893	HSK - B 40			
X	DIN 69871	SK 30	(BT 30)		
L	DIN 69871/69872	SK 50	ISO 50	CUT 50	CTM 50
E	DIN 69893	HSK - A 80			
H	DIN 69893	HSK - B 80			
P	DIN 69893	HSK - A 100			
U	DIN 69893	HSK - B 100			
Z	JIS B6339	SK 50	(BT 50)		
S	Special taper must be identify by the complete identification code.				

25.- Designation of gripper arm BP

CHANGE ARM (gripper arm)

BP 40 - D - A - 450

- Size series _____
- Direction of rotations _____
 D=Clockwise
 S=Counterclockwise
- Type of taper (A,.....,H See table par. 28) _____
- Distance between grippers _____

EXAMPLE: Gripper arm for SK 40 taper with gripper distance 450 mm

GRIPPER ARM BP 40 - D - A - 450



26. - Exchange time diagram CUT 31

N.B. : “ In the case of positioning the CUT with horizontal axis and in the presence of loads highly unbalanced; do not consider the data applied on the chart, but contact our technical office.”

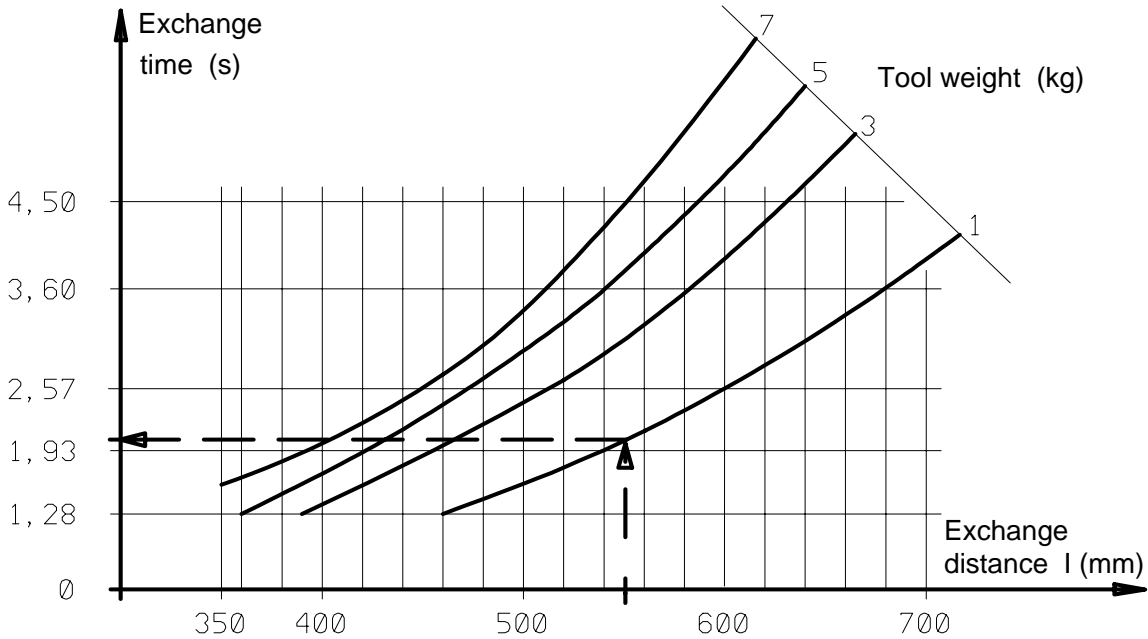

Fig. 22

Example: Tool weight 1 [kg], exchange distance 550 [mm], can be changed in an exchange time of 2.09 [s]

27. - Exchange Time diagram CUT 41

N.B. : “ In the case of positioning the CUT with horizontal axis and in the presence of loads highly unbalanced; do not consider the data applied on the chart, but contact our technical office.”

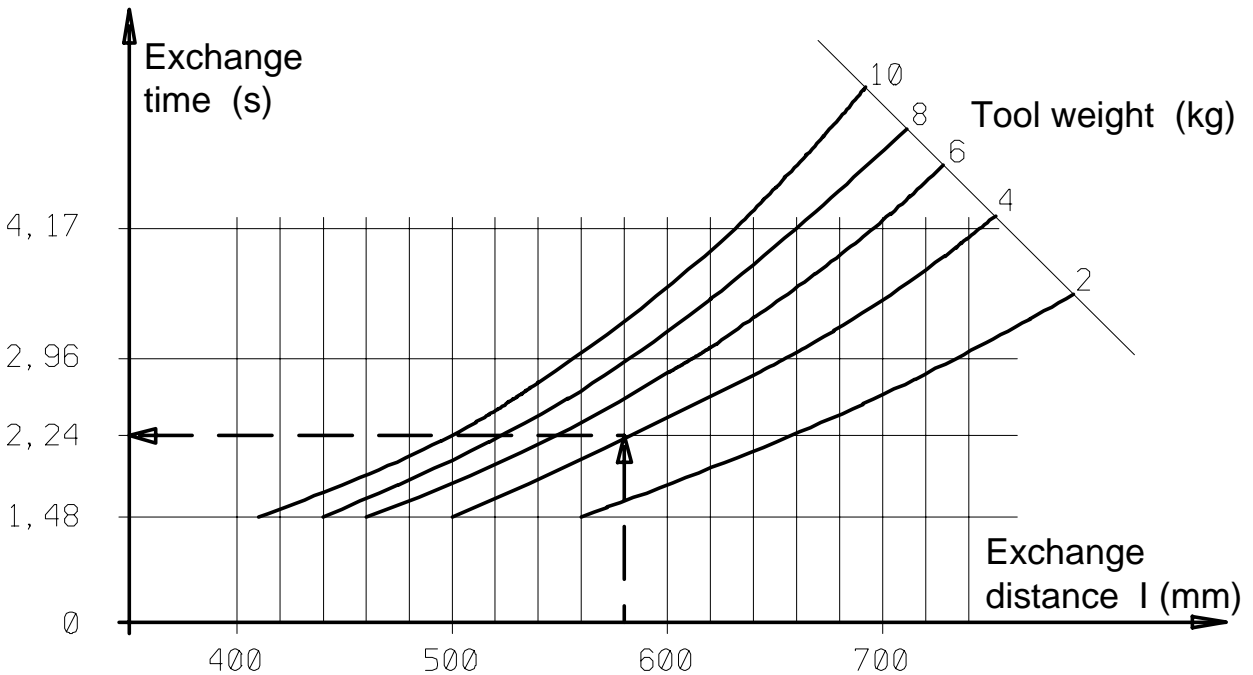

Fig. 24

Example: Tool weight 4 [kg], exchange distance 580 [mm], can be changed in an exchange time of 2.24 [s]

28. - Exchange Time diagram CUT 51

N.B. : " In the case of positioning the CUT with horizontal axis and in the presence of loads highly unbalanced; do not consider the data applied on the chart, but contact our technical office."

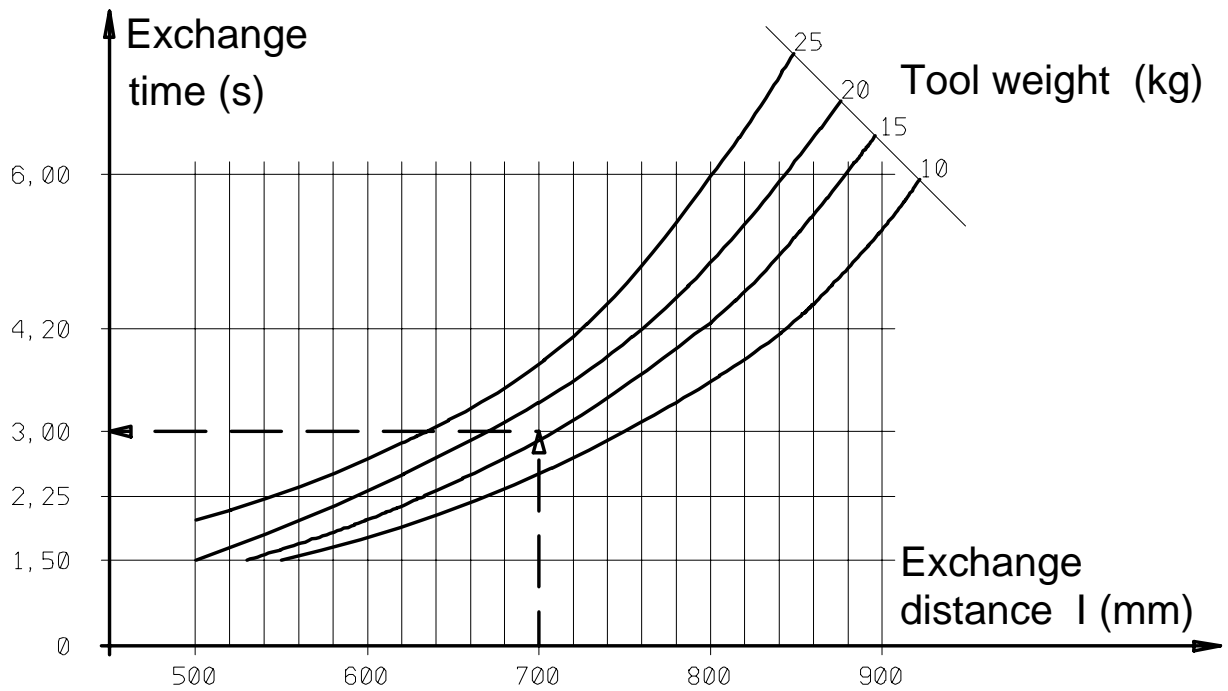

Fig. 26

Example: Tool weight 15 [kg], exchange distance 700 [mm], can be changed in an exchange time of 3.00 [s]





Collaborative Engineering