

CF3 TANDEM
65T•80T•105T•130T
TANDEM



- Cuboid shaped, super strong, cast iron housing.
- hardened and ground plate cams.
- Shafts located in taper roller bearings.
- Integrated worm gear reducer.
- Contained dimensions.
- Mechanical synchronization of the cycle.
- Noiseless and sweetness of the movements.
- Reduced maintenance.
- Vast range of standard movements.



COLOMBO FILIPPETTI SPA
COLLABORATIVE ENGINEERING

CF1351 10-03

Via Rossini, 26 I-24040 CASIRATE D'ADDA -BG -Tel 0363-3251 Fax 0363-325252
<http://www.cofil.it> - E-mail cofil@cofil.it

The INTERMICO Tandem of the series "T" has one compact structure, with hardened and grinding cams to positive joining. The intermittent cam mechanisms produce the two output movements.

The rotatory and oscillating movements of the output shafts occur on a same plain, which is orthogonal to the same output shaft.

The possible versions of the mechanisms are: Tandem with intermittent and unidirectional motion, Tandem with intermittent and oscillating motion, or a combination of an unidirectional motion with an oscillating motion



Contents**PAG**

1.	Introduction.....	2
2.	Definition of the terms	5
3.	Introduction.....	6
4.	Index drive	10
5.	Oscillating drives	13
6.	Sizing	18
7.	Assembly	19
8.	Synchronization(phase setting)	21
9.	Version	22
10.	Mounting positions	22
11.	Designation	23
12.	Overall dimensions	24
13.	Application examples	26

The units of measurement correspond with System International /Severity Index SI General tolerances of manufacture are conform to UNI – ISO 2768-1 UNI EN 22768-1

Illustrations and drawings according to UNI 3970 (ISO 128-82).

Method of projection of the drawings.

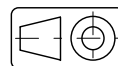

All rights reserved. No part of this catalogue may be duplicated.

COLOMBO FILIPPETTI may make any changes they feel necessary for the improvement of their products without advance notice.

COLOMBO FILIPPETTI may change any market components and accessories mentioned in this catalogue as they feel necessary.

This catalogue supersedes all earlier ones



1. INTRODUCTION

Its simple design, its ability to transform motion directly, the laws of motion it implements, with mathematically defined accelerations tested in a large number of applications, the positive and continuous control it is subject to throughout the motion, along with the extensive experience in the calculation, manufacture and applicability of cam-driven mechanisms which have gone into the TANDEM CF3 make of it a top-quality and highly reliable product that provides all those characteristics of accuracy, high speed, low vibrations, smooth, regular, low-noise operation and perfectly repeatable movements as well as application versatility which the most highly advanced automatic machines and motion systems require.

These characteristics of TANDEM CF3, available as a standard in several dimensions, with a great number of standard movements and combination possibilities, make it possible to solve the most various problems in the best and simplest of ways by exploiting the conjugate cams drive technology at very low costs and minimized design, engineering and implementation costs. For the same reason also the execution of some special (non-standard) motions is kept at very low cost. These are fitted whenever possible in the box of TANDEM CF3 or else taking advantage of the internal components of standard TANDEM CF3.

1.1 How the Tandem works

The TANDEM CF3 is a mechanism achieved by combining in one box, two double set of CF3 conjugate cams and their respective rotary follower turrets. The uniform rotation of the one input shaft is transformed by this mechanism into 2 intermittent rotary motion output shafts. Each intermittent motion output shaft can be unidirectional or oscillating as required at the specifying stage. There is a free choice and it is possible to have:

- An intermittent rotation + oscillator (intermitter+oscillator)
- 2 intermittent rotation (intermitter + intermitter)
- 2 oscillator (oscillator + oscillator)

1.2 Characteristics

The (normally) cast-iron box of TANDEM CF3 is a cuboid of great strength and rigidity with all faces machined and which can be mounted in any plane.

The cams are in hardened and ground steel. The roller followers are supported in a turret to ensure the maximum rigidity of transmission. The input and output shafts are parallel with taper roller bearings at each end. Motion may be supplied, in addition to the main input shaft, also to the fast shaft of a worm screw-ring reduction gear which may be mounted within the box without increasing its overall dimensions.

1.3 Where the Tandems are used

TANDEM CF3 mechanisms are used in assembly, control, packing, handling machines, presses, multiple station transfer machines, welding machines and generally in all applications where two intermittent motions are required to operate in perfect synchronism with each other.

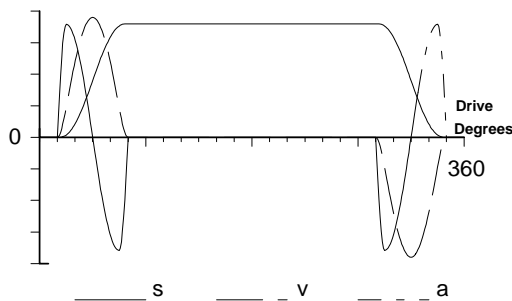

Fig. 1 Diagram of oscillating motion

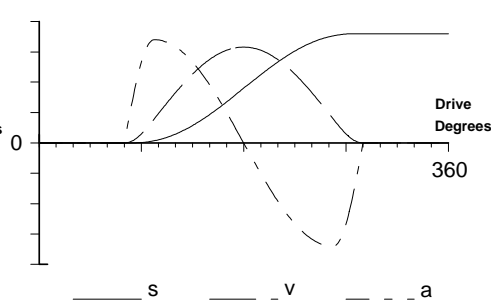

Fig. 2 Diagram of indexing motion

1.4. Danger area

Since this is a positive-action device, a gripper arm or a tool plate mounted on output shaft 1 and 2 moves only within its area.

Its motion may be altered only by switching off the driving motor. The torque limiter is to protect the device motor. The torque limiter is to protect the device against jams. It cannot protect persons.

Therefore, the danger area should not be accessed whilst the device is in operation.

For maintenance operations, the motor must be switched off before crossing into the danger area.

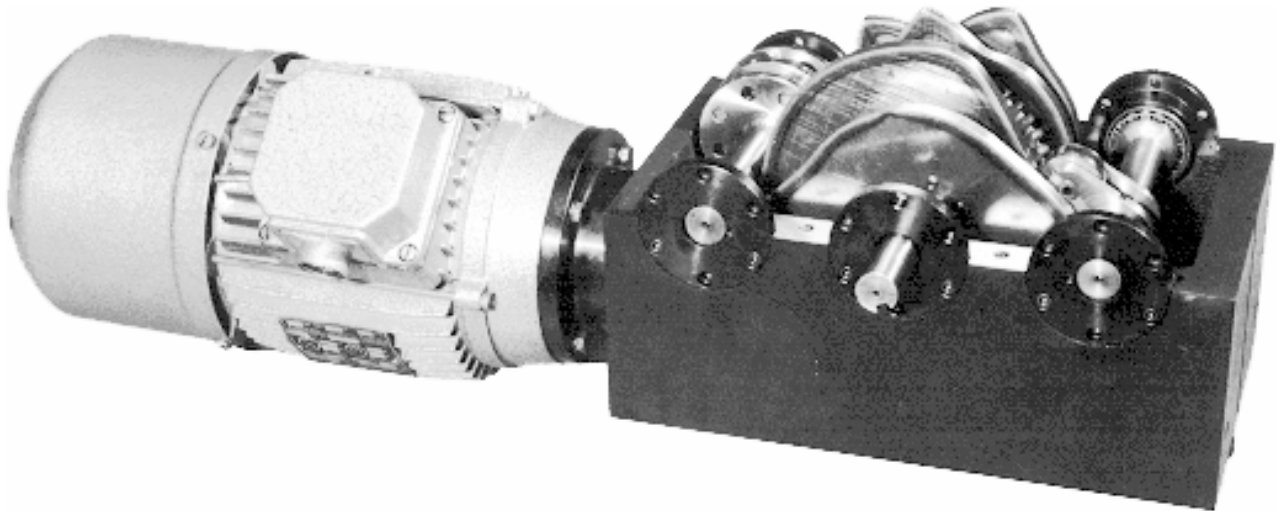

Fig. 3 - Split view of TANDEM CF3 complete with built-in worm speed reducer and attached self-braking motor.

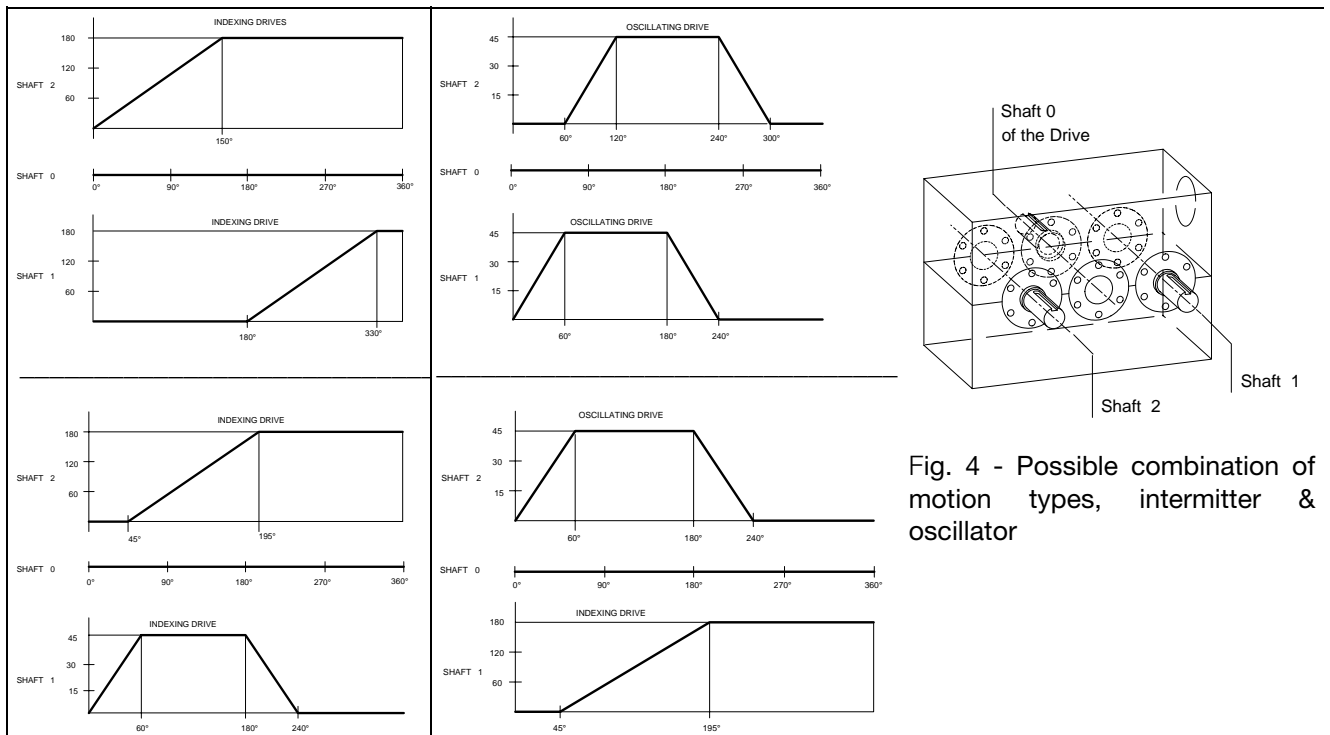

Fig. 4 - Possible combination of motion types, intermitter & oscillator

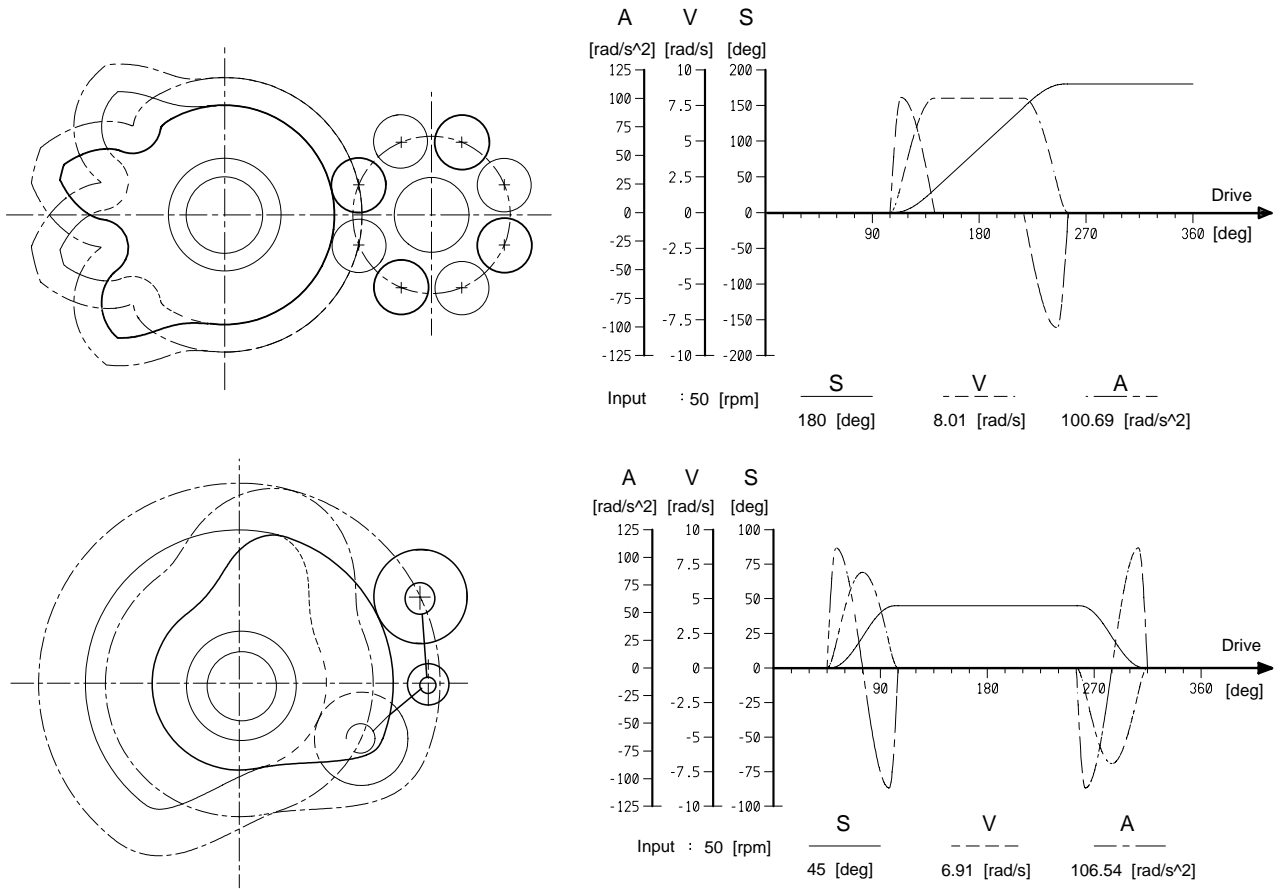

Fig. 5 - Computerized plotting of S-V-A curves and profiles of index drive (above) and oscillating drive (below).

2. DEFINITION OF THE TERMS

OSCILLATING DRIVE	A cam and feeler operated transmission mechanism which converts the continuous rotary motion of the "drive" into the intermittent oscillating motion of the "driven". The typical cycle of the "driven" is "index - dwell - return - dwell".
INDEX DRIVE	A cam and feeler operated transmission mechanism which converts the continuous rotary motion of the "drive" into the intermittent one-way motion of the "driven". The typical cycle of the "driven" is "index - dwell".
CAM	It is the driving element of the transmission mechanism, whether oscillating or index drive. The shape of its profile determines the movement obtained at the output of the driven.
ROLLER LEVER	It is the driven element of the oscillating mechanism.
ROLLER PLATE	It is the driven element of the indexing mechanism.
INPUT SHAFT (synchronization shaft)	This is the (drive) camshaft which carries, when required, the ring of the worm screw reduction gear. The input shaft is identified by no. "0".
OUTPUT SHAFT	This is the (driven) roller lever or plate shaft. Output shafts are identified by nos. "1" and "2".
NUMBER OF REVOLUTIONS	[rpm] speed of rotation of the input shaft.
NUMBER OF CYCLES	[cpm] speed of rotation of the output shafts with continuously rotating input shaft.
INDEXING (DISPLACEMENT) ANGLE	Angle of rotation of the input shaft during which one complete turn of the output shaft takes place.
DWELL ANGLE	Angle of rotation of the input shaft during which the output shaft stops.
ANGULAR STROKE	Amplitude of the angular oscillation of the oscillating drive output shaft.
NUMBER OF STATIONS	Number of stops which the index drive output shaft makes during one complete turn.
OUTPUT TORQUE DURING MOTION	Total of all torque required during the displacement of the output shaft: moment of inertia, friction and torque due to external or operating forces.
OUTPUT TORQUE DURING DWELL	Total of all torque required during dwell time of the output shaft due to unbalanced loads, operating forces, etc.
INPUT TORQUE	Input torque required at input shaft "0".
COEFFICIENT OF VELOCITY	Characteristic value of the law of motion corresponding to top speed.
COEFFICIENT OF ACCELERATION	Characteristic value of the law of motion corresponding to maximum acceleration.
COEFFICIENT OF TRANSMISSION	Value which makes it possible to establish the maximum torque required at the input shaft during motion.
LIFE	The values in the tables are based on 8,000 hours of operation.



3. GENERAL

3.1 Box

The sturdy, rigid cast-iron box has a prismatic shape and all its surfaces are machined. This makes it possible for the user to mount it in any position. Fastening holes of standard size have been drilled into the "C-D-E-F" lateral surfaces. Sides "A" and "B", containing the main shafts, can be drilled to a depth of 20 mm at most, avoiding the ties which couple both halves of the box. The size of the casing is such as to assure a good supply of oil and thermal capacity. The protective phosphate coat does not affect the size and characteristics of the surfaces nor their functions, and confers to them their characteristic and attractive brown colour.

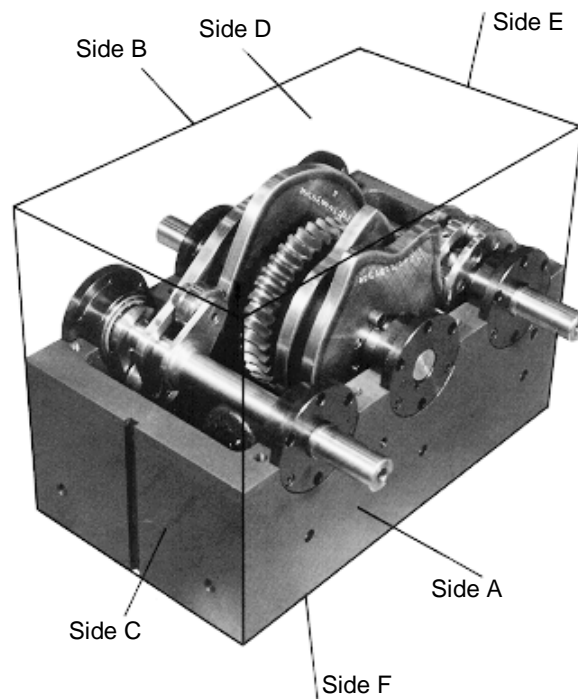

Fig. 6

3.2 Gearing

The gearing which converts the continuous rotary motion has parallel axes and consists of (drive) steel cams with hardened and ground conjugate profiles on which the (driven) needle rollers of the feeler turn opposite each other. Their special design and dimensions as well as the yoke support, assure perfectly kept synchronism, maximum drive rigidity and a high torque even at high speeds. The rolling contact and the possibility to preload the rollers on the profiles also assure absence of backlash, high transmission efficiency, low profile wear and positive and continuous motion control by perfect matching between output rotation (of the drivens) and input rotation (of the drive).

The worm screw reduction gear, an optional extra, was designed to meet the special requirements of these assemblies and can be built into the box without increasing its overall dimensions. Such a solution improves the versatility of the TANDEM CF3 mechanism and provides it with a rigid and extremely compact system. The wide range of available reduction ratios meets the most various application requirements.

3.3 Shafts

The shafts of TANDEM CF3 are made of hardened and tempered steel. Diameters and end lengths are in conformity with UNI 6397-68 (DIN 748 - ISO/R 775-69). They are sized to withstand the bending and torsional stresses to which they are submitted with an ample safety margin.

3.4 Seals

In order to assure top reliability of the rotary seals, sealing rings with dust-proof lip are used. The gap between the lips is filled in with grease. Static seals are made of anaerobic materials with high resistance to heat, humidity and chemicals which by assuring metal-on-metal contact, prevent the screws from gradually fastening loose and do not affect machining tolerances.

3.5 Bearings

The choice of opposed taper roller bearings for supporting the shafts, and coupled taper roller bearings plus a straight roller bearing of the screw shaft only in series 65 T, was made to meet in-house size standardization requirements and to assure a wide range of conditions of use.

3.6 Lubrication

Special attention has been addressed to oil bath lubrication and to the way to minimize maintenance operations. On TANDEM CF3 drives running at low and medium speeds, i.e. < 200 cycles/min, long-life lubrication with mineral oil is recommended. The boxes are supplied without the oil level and drain plugs, already contain the appropriate quantity of lubricant, do not require maintenance and allow greater flexibility in mounting.

On TANDEM CF3 drives running at medium to high speeds, i.e. > 200 cycles/min., the lubricant requires regular changing. The boxes are fitted with fill-level-drain plugs and are delivered without lubricant; the requisite amount of oil will need to be filled in by the buyer before starting up. The lubricant requires changing every 8000 hours of operation and in any case not more than two years should elapse between each oil change and the next.

RECOMMENDED LUBRICANTS

ISO/UNI	VG 150
AGIP	BLASIA 150
BP	ENERGOL GR 150 XP
ESSO	SPARTAN EP 150
FINA	GIRAN 150
MOBIL	MOBIL GEAR 629
SHELL	OMALA OIL 150

When changing the lubricant, before unscrewing the drain plug, wait for oil to get cold.

Drain off oil completely and screw drain plug back into place.

Top up to the prescribed level through charging hole, see 12.1

3.7 Drive system

Two different ways of conveying motion to TANDEM CF3 drives have been provided: the first consists in driving the input (or synchronizing) shaft "Ø" directly, the second in driving the worm screw reduction gear shaft.

The choice of one or the other system depends on requirements and on the design of the application.

In particular, if the TANDEM CF3 mechanism is applied to a machine tool and is supposed to turn in a 1:1 ratio with the main machine shaft, input shaft "Ø" should be driven directly. If the main machine shaft is a fast shaft with regard to the cycle, the worm screw shaft should be chosen as well as the most indicated reduction ratio. The second solution is in any case advisable as it makes it possible to obtain transmission with a better torsional rigidity.

If the TANDEM CF3 drive is not required to be mechanically synchronized with a machine tool, it can be powered directly by keying an electrical motor to the internal worm screw shaft via a flange and coupling.

3.8 Response operation

In many applications where mechanical synchronism between the operating cycle of the TANDEM CF3 mechanism and the cycle of the machine is not required or cannot be obtained since the operating times of the machine, corresponding to the dwell times of the TANDEM, are very long compared to the motion times, electrical synchronism may be implemented through response operation of TANDEM CF3.

In this type of application, the TANDEM CF3 drive usually performs a complete cycle, corresponding to one turn of the input shaft, and is then halted while awaiting response before proceeding to the next cycle. This stop of the drive system, which is essentially an extension of the dwell time and therefore of the total cycle time of TANDEM CF3, may be executed by means of a cam which controls a limit switch. This limit switch sends a stop signal to a self-braking motor or a disengaging signal to a clutch brake assembly mounted between the worm screw fast shaft and the shaft of an electric motor. The limit switch control shaft is keyed to the TANDEM CF3 drive input shaft "Ø" - which is also the synchronizing shaft - in such a position that the stop occurs at a point of the cycle where the movements of the shafts "1" and "2" are in dwell at the same time. Non-synchronized stop of the movements of TANDEM CF3 should be avoided, as it causes damage and breakdowns. During emergency stops, or stops at the end of the work shift, these directions should be taken into account.

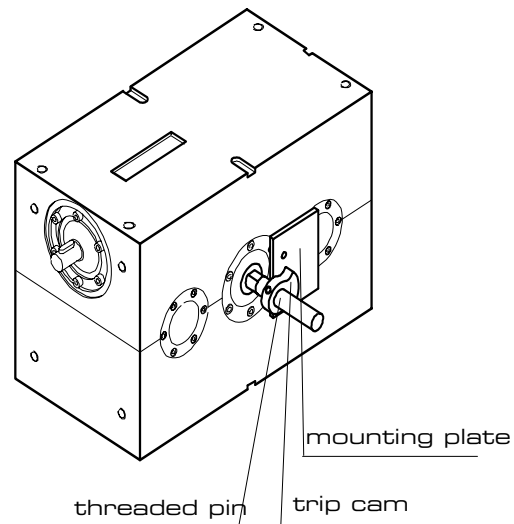

Fig. 7 - Response operation - location of the limit switch control cam

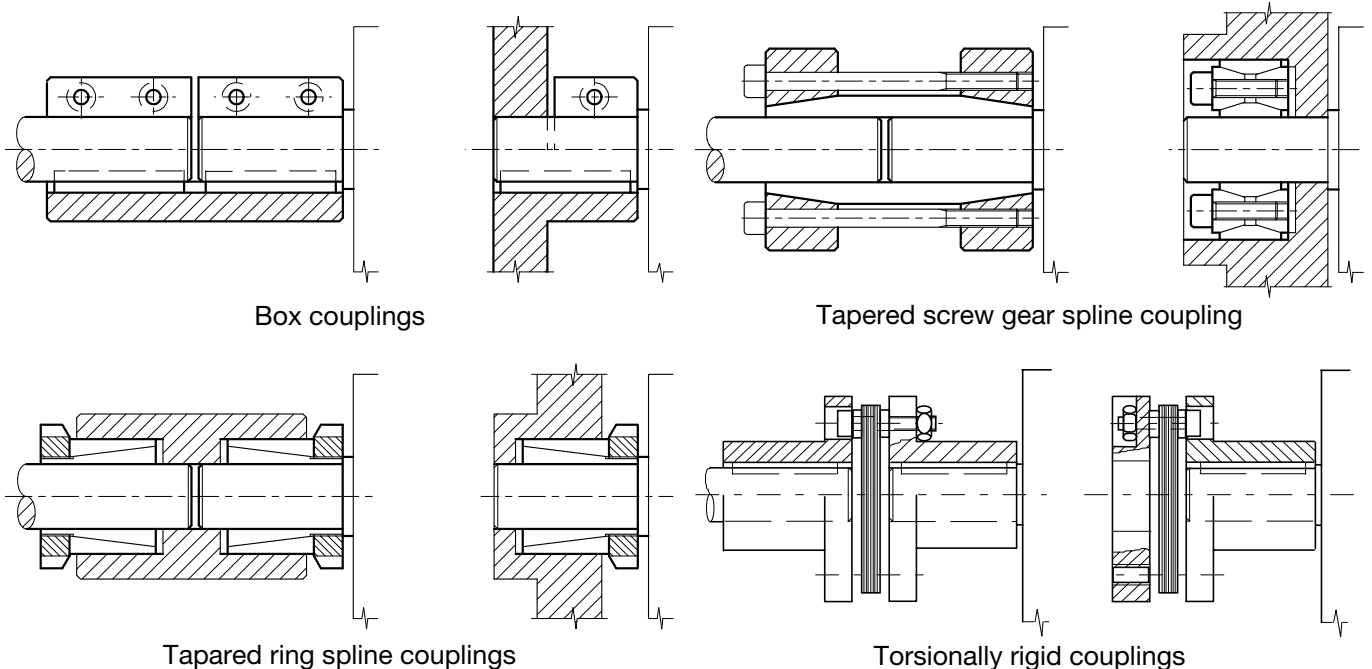

Fig. 8 - Output connection with a sleeve coupling or tapered keying with screw ring

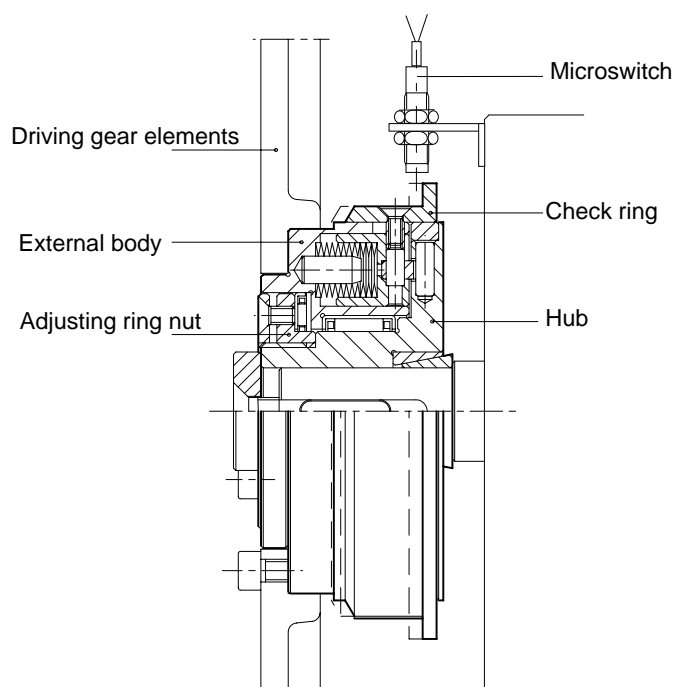

Fig. 9 - COLOMBO FILIPPETTI GSR type resynchronising safety coupling.

3.9 Application advice

On mechanisms which produce non-uniform motion, during each cycle, moving parts must undergo acceleration from rest to top speed and deceleration from top speed to rest. The TANDEM CF3 drive must therefore supply an alternating torque whose progress is similar to that of the acceleration curve of the law of motion applied. This torque, having variable intensity, tends to change the speed of rotation of the input shaft, causing it to pulsate within the indexing - dwell cycle. This requires particular attention in the design of the TANDEM CF3 output and input transmission elements.

For these reasons it is essential:

- To avoid at all costs any backlash and elasticity both of the input and of the output transmission elements.
- To determine the sizes of torsional stress-resistant rigid and lightweight components at the output.
- To determine the sizes of torsional stress-resistant rigid components at the input, with an ample safety margin.
- To mount a worm screw whenever possible.
- To apply safety devices on the output shaft to protect it against overloads damaging the mechanism. We recommend our "GSR" re-synchronizing safety couplings.

4. INDEX DRIVE

4.1 Indexing diagram

In indexing motion, the number of stops (intermittences) which the output shaft makes while performing one full turn is called the "NUMBER OF STATIONS" and is indicated in the catalogues with the letter "S". The angle of stroke through which the output shaft turns during one cycle, corresponding to the displacement travelled from one station to the next, is called "ANGULAR STROKE" and its value is expressed by the equation $H^\circ = 360^\circ/S$ [degrees].

A full cycle, consisting of a displacement from one station to the next and a dwell at the station, performed by the driven is usually produced during one full turn through 360° [degrees] performed by the input (drive) shaft.

In standard mechanisms, a turn of the input shaft is divided into two periods or angles, which are called, according to the order in which they are executed:

- I - INDEX ANGLE, indicated with B
- II - DWELL ANGLE, indicated with B_p .

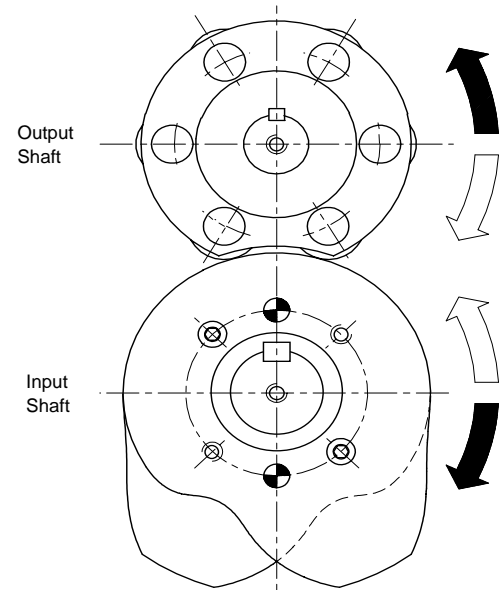

Fig. 10

The point which gives origin to this succession is the "CYCLE START" point, which is always followed by the period or index angle "B" regardless of the direction of rotation of the input shaft "Ø", but bearing in mind that the rotation of the output shaft will always take place in the opposite direction. When the indexing mechanism drives the output shaft "1", the "SYNCHRONIZING AXIS", which matches the axis of the feather of the input shaft "Ø", is always located half-way through the dwell angle " B_p ".

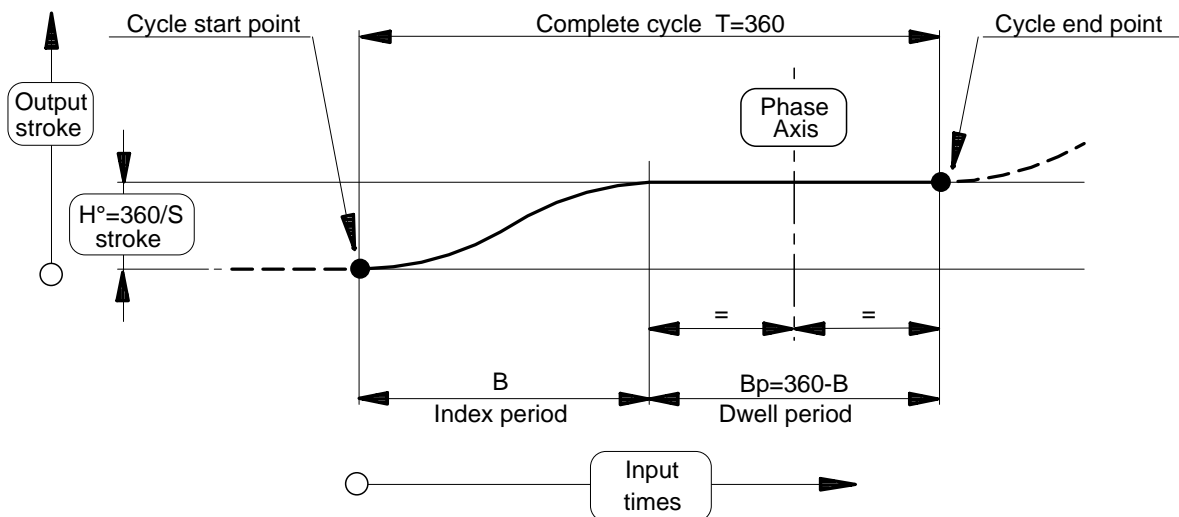

Fig. 11

4.2 SPECIFICATIONS

INDEX DRIVE CODE				Static Torque Ms [daN m]	Dynamic output torque Mu [daN m]						Velocity factor Cv	Acceleration factor Ca	Input torque factor K	
SERIES	Number of Stops S	Index period B° [deg]	Dwell period Bp° [deg]											
					50 cycles/1'	100 cycles/1'	200 cycles/1'	300 cycles/1'	400 cycles/1'	500 cycles/1'				
65 T	1	180	180	7,5	5,3	5,1	4,1	3,5	3,1	2,7	1.27	8.01	1.43	
80 T				14,5	11,5	10,5	8,3	7,1	6,2	5,5				
105 T				30,0	25,3	21,6	17,1	14,6	12,8	11,3				
130 T				57,0	47,4	38,3	30,5	26,0	22,8	20,1				
65 T		210	150	150	7,5	5,3	4,3	3,4	2,9	2,5	2,2	1.35	7.02	1.30
80 T					14,5	11,0	8,8	7,0	5,9	5,2	4,6			
105 T					30,0	22,3	18,0	14,3	12,2	10,7	9,4			
130 T					57,0	39,6	32,0	25,4	21,7	19,0	16,8			
65 T		240	120	120	7,5	4,7	3,8	3,0	2,6	2,3	2,0	1.40	6.62	1.18
80 T					14,5	9,8	7,9	6,3	5,4	4,7	4,2			
105 T					30,0	20,0	16,1	12,8	11,0	9,6	8,4			
130 T					57,0	35,5	28,7	22,8	19,5	17,0	15,0			
65 T		270	90	90	7,5	4,6	3,7	2,9	2,5	2,2	1,9	1.40	6.62	1.05
80 T					14,5	9,3	7,5	6,0	5,1	4,5	3,9			
105 T					30,0	19,1	15,5	12,3	10,5	9,2	8,1			
130 T					57,0	34,0	27,5	21,8	18,6	16,3	14,4			
65 T		300	60	60	7,5	6,1	5,0	3,9	3,4	2,9	2,6	1.27	8.01	0.86
80 T					14,5	12,6	10,2	8,1	6,9	6,0	5,3			
105 T					30,0	25,8	20,8	16,5	14,1	12,4	10,9			
130 T					57,0	46,9	37,9	30,1	25,7	22,5	19,8			
65 T	330	30	30	7,5	5,3	4,3	3,4	2,9	2,6	2,3	1.35	7.02	0.83	
80 T				14,5	10,9	8,8	7,0	6,0	5,2	4,6				
105 T				30,0	22,4	18,1	14,4	12,3	10,7	9,5				
130 T				57,0	40,5	32,7	26,0	22,2	19,4	17,1				
65 T	2	90	270	6,0	5,2	5,2	5,0	4,8	4,5	4,1	1.27	8.01	1.43	
80 T				13,0	11,2	11,1	10,7	9,9	8,9	7,6				
105 T				27,0	24,8	24,4	22,9	20,5	17,0	12,5				
130 T				52,0	46,2	44,9	39,9	31,5	19,8	15,8				
65 T		120	240	240	6,0	4,9	4,9	4,8	4,7	4,5	4,2	1.27	8.01	1.07
80 T					13,0	10,7	10,6	10,3	9,9	9,3	8,6			
105 T					27,0	23,6	23,4	22,6	21,1	19,2	16,6			
130 T					52,0	44,1	43,4	40,5	35,8	29,1	20,5			
65 T		150	210	210	6,0	4,8	4,7	4,6	4,3	4,0	3,6	1.27	8.01	0.86
80 T					13,0	10,2	10,1	9,7	9,1	8,3	7,3			
105 T					27,0	22,7	22,4	21,4	19,7	17,4	14,6			
130 T					52,0	43,2	42,4	39,7	35,1	28,9	21,2			
65 T		180	180	180	6,0	4,8	4,8	4,5	3,9	3,4	3,0	1.40	6.62	0.79
80 T					13,0	10,4	10,3	9,2	7,9	6,9	6,1			
105 T					27,0	23,1	22,9	19,0	16,2	14,2	12,5			
130 T					52,0	43,9	43,2	34,4	29,4	25,7	22,7			
65 T		210	150	150	6,0	4,9	4,8	4,2	3,6	3,2	2,8	1.40	6.62	0.68
80 T					13,0	10,4	10,4	8,6	7,4	6,5	5,7			
105 T					27,0	23,2	22,5	17,9	15,3	13,3	11,8			
130 T					52,0	44,2	40,8	32,4	27,7	24,2	21,4			
65 T	240	120	120	6,0	4,9	4,9	4,0	3,5	3,0	2,7	1.40	6.62	0.59	
80 T				13,0	10,5	10,3	8,2	7,0	6,1	5,4				
105 T				27,0	23,5	21,4	17,0	14,5	12,7	11,2				
130 T				52,0	44,6	38,8	30,8	26,4	23,0	20,3				
65 T	270	90	90	6,0	5,5	4,8	3,8	3,3	2,8	2,5	2.00	6.28	0.87	
80 T				13,0	11,8	9,9	7,9	6,7	5,9	5,2				
105 T				27,0	25,2	20,4	16,2	13,8	12,1	10,7				
130 T				52,0	45,4	36,6	29,1	24,9	21,8	19,2				

INDEX DRIVE CODE				Static Torque Ms [daN m]	Dynamic output torque Mu [daN m]						Velocity factor Cv	Acceleration factor Ca	Input torque factor K	
SERIES	Number of Stops S	Index period B° [deg]	Dwell period Bp° [deg]		50	100	200	300	400	500				
					cycles/1'	cycles/1'	cycles/1'	cycles/1'	cycles/1'	cycles/1'				
65 T	3	90	270	7,5	6,2	6,2	6,1	5,9	5,2	4,6	1.27	8.01	0.55	
80 T				14,5	13,4	13,4	13,1	12,1	10,6	9,3				
105 T				30,0	29,8	29,5	28,6	25,1	21,9	19,4				
130 T				57,0	55,6	54,9	51,7	44,4	38,9	29,5				
65 T		120	240	240	7,5	5,6	5,5	5,3	5,1	4,7	4,3	1.40	6.62	0.79
80 T					14,5	12,0	11,9	11,5	10,8	10,0	8,9			
105 T					30,0	26,6	26,3	25,3	23,6	20,8	18,4			
130 T					57,0	50,3	49,7	47,1	42,8	37,1	30,1			
65 T		150	210	210	7,5	5,5	5,5	5,3	4,9	4,3	3,8	1.40	6.62	0.63
80 T					14,5	11,9	11,8	11,4	10,0	8,8	7,8			
105 T					30,0	26,3	26,1	24,3	20,8	18,2	16,0			
130 T					57,0	49,9	49,4	44,3	37,9	33,1	29,2			
65 T		180	180	180	7,5	6,2	5,7	4,6	3,9	3,4	3,0	1.76	5.53	0.66
80 T					14,5	13,3	11,8	9,4	8,0	7,0	6,2			
105 T					30,0	29,4	24,4	19,4	16,5	14,5	12,8			
130 T					57,0	54,3	43,9	34,9	29,8	26,1	23,0			
65 T		210	150	150	7,5	6,0	5,5	4,4	3,7	3,3	2,9	1.76	5.53	0.56
80 T					14,5	13,0	11,3	9,0	7,7	6,7	5,9			
105 T					30,0	28,7	23,2	18,4	15,7	13,8	12,1			
130 T					57,0	51,8	41,9	33,3	28,3	24,9	21,9			
65 T		240	120	120	7,5	5,8	5,3	4,2	3,6	3,1	2,8	1.76	5.53	0.49
80 T					14,5	12,6	10,8	8,6	7,4	6,4	5,7			
105 T					30,0	27,6	22,3	17,7	15,1	13,2	11,7			
130 T					57,0	49,9	40,3	32,0	27,4	23,9	21,1			
65 T		270	90	90	7,5	5,7	5,1	4,1	3,5	3,0	2,7	1.76	5.53	0.44
80 T					14,5	12,3	10,4	8,3	7,1	6,2	5,5			
105 T					30,0	26,6	21,5	17,1	14,6	12,8	11,3			
130 T					57,0	48,1	38,9	30,9	26,4	23,1	20,4			
65 T	4	60	300	6,0	5,1	5,1	4,9	4,7	4,4	3,9	1.27	8.01	1.07	
80 T				13,0	11,1	10,9	10,5	9,7	8,5	7,1				
105 T				27,0	24,5	24,1	22,4	19,6	15,7	10,7				
130 T				52,0	45,7	44,3	38,6	29,2	20,0	13,3				
65 T		90	270	270	6,0	5,5	5,5	5,4	5,3	5,2	4,9	1.37	6.45	0.73
80 T					13,0	11,8	11,8	11,6	11,3	10,9	10,0			
105 T					27,0	26,3	26,2	25,5	24,5	23,0	20,6			
130 T					52,0	50,0	49,5	47,4	43,9	39,1	32,8			
65 T		120	240	240	6,0	4,8	4,8	4,6	4,3	3,8	3,3	1.76	5.53	0.74
80 T					13,0	10,3	10,2	9,9	8,8	7,7	6,8			
105 T					27,0	22,9	22,7	21,3	18,2	15,9	14,0			
130 T					52,0	43,5	43,0	38,5	32,9	28,8	25,4			
65 T		150	210	210	6,0	4,9	4,8	4,7	4,0	3,5	3,1	1.76	5.53	0.59
80 T					13,0	10,5	10,4	9,5	8,2	7,1	6,3			
105 T					27,0	23,2	23,1	19,7	16,8	14,7	13,0			
130 T					52,0	44,2	43,7	35,7	30,5	26,6	23,5			
65 T		180	180	180	6,0	5,0	4,9	4,4	3,7	3,3	2,9	1.76	5.53	0.49
80 T					13,0	10,7	10,6	8,9	7,6	6,6	5,9			
105 T					27,0	23,7	23,1	18,4	15,7	13,7	12,1			
130 T					52,0	45,0	41,9	33,3	28,5	24,9	22,0			
65 T		210	150	150	6,0	5,0	5,0	4,1	3,5	3,1	2,7	1.76	5.53	0.42
80 T					13,0	10,8	10,6	8,4	7,2	6,3	5,5			
105 T					27,0	24,0	21,9	17,4	14,8	13,0	11,5			
130 T					52,0	45,6	39,7	31,5	26,9	23,6	20,8			
65 T		240	120	120	6,0	5,0	5,0	4,0	3,4	3,0	2,6	1.76	5.53	0.37
80 T					13,0	10,7	10,2	8,1	6,9	6,0	5,3			
105 T					27,0	23,7	21,0	16,7	14,3	12,5	11,0			
130 T					52,0	44,9	38,1	30,3	25,9	22,6	20,0			
65 T	270	90	90	6,0	4,9	4,8	3,8	3,3	2,9	2,5	1.76	5.53	0.33	
80 T				13,0	10,6	9,8	7,8	6,6	5,8	5,1				
105 T				27,0	23,5	20,2	16,1	13,7	12,0	10,6				
130 T				52,0	44,5	36,7	29,2	24,9	21,8	19,2				

5. OSCILLATING DRIVE

5.1 Displacement diagram

In oscillating movements, the extent of oscillation of the output shaft is called "ANGULAR STROKE" and is indicated by the letter "H".

The complete cycle - which is composed of two rotations having the same amplitude but opposite directions (oscillation), with or without intermediate dwell times - is produced by one complete rotation (360°) of the input shaft.

This cycle, on our standard mechanisms, is divided into four angles or periods defined as follows, according to the order of execution:

- I - TIME OF DISPLACEMENT, indicated with "A"
- II - DWELL TIME, indicated with "B"
- III - TIME OF DISPLACEMENT, indicated with "C"
- IV - DWELL TIME, indicated with "D".

The point from which this succession in time originates is the "CYCLE START" point; this point is always followed by the TIME OF DISPLACEMENT "A" regardless of the direction of rotation of the input shaft and regardless of the required direction of rotation of the output shaft during this period. When the oscillating drive actuates the motion of output shaft "1", the SYNCHRONIZING AXIS, which coincides with the axis of the feather of the input shaft "Ø", is always located half-way through the displacement period "A".

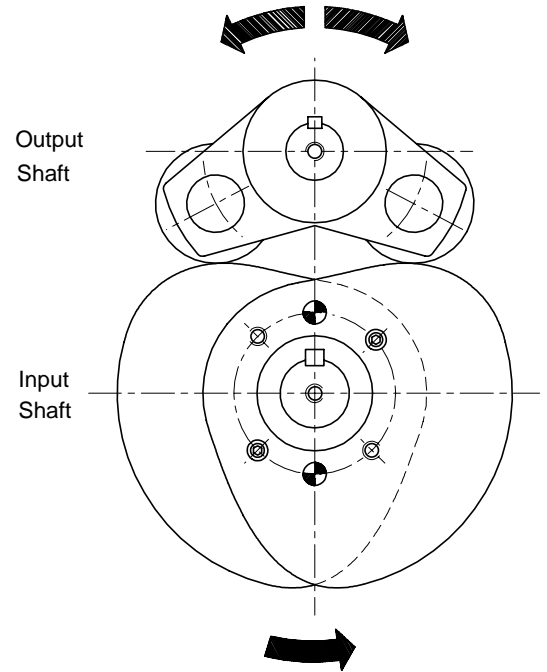

Fig. 12

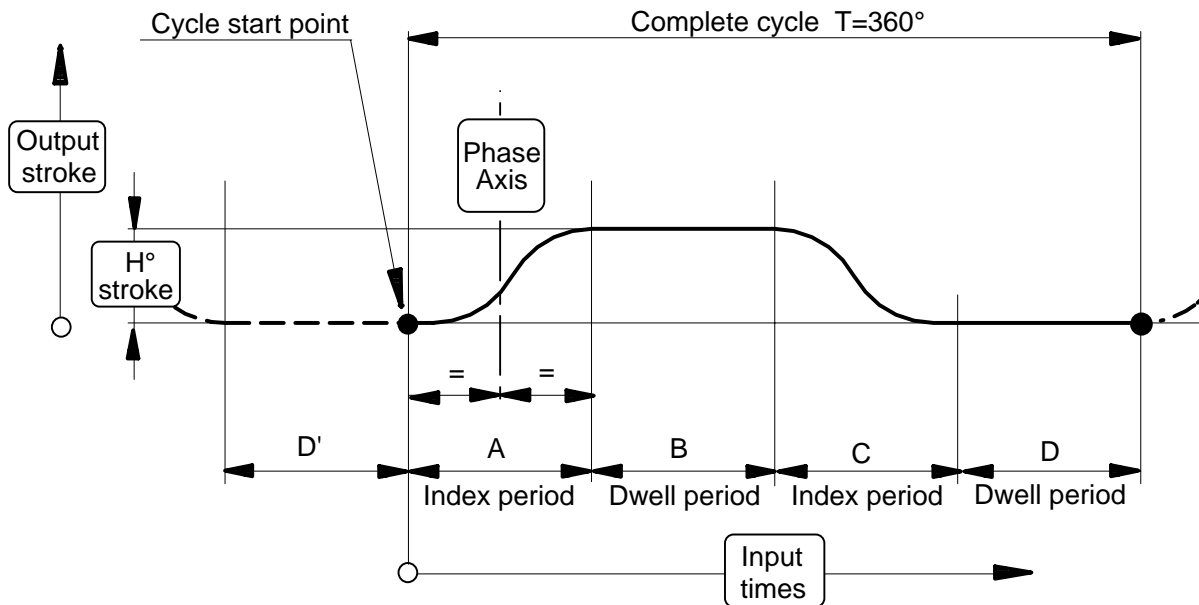

Fig. 13

5.2 Specifications

SERIES	Angular stroke H° [deg]	OSCILLATING DRIVE CODE				Static torque Ms [daN m]	Dynamic output torques Mu [daN m]						Acceleration factor Ca	Input torque factor K
		PERIODS T° [deg] OF CYCLE					50 cycles/1'	100 cycles/1'	200 cycles/1'	300 cycles/1'	400 cycles/1'	500 cycles/1'		
		A motion	B dwell	C motion	D dwell									
65 T	15	30	150	30	150	8,9	6,6	6,5	5,1	4,4	3,8	3,4	5.53	0.49
80 T						19,4	14,0	12,9	10,3	8,8	7,7	6,8		
105 T						34,5	25,7	21,9	17,4	14,9	13,0	11,5		
130 T						97,7	64,7	60,5	48,1	41,1	35,9	31,7		
65 T		30	300	30	0	8,9	6,6	6,6	5,2	4,5	3,9	3,4	5.31	0.47
80 T						19,4	14,1	13,1	10,4	8,9	7,8	6,9		
105 T						34,5	25,5	22,3	17,7	15,1	13,2	11,7		
130 T						97,7	64,4	61,2	48,7	41,6	36,3	32,1		
65 T		45	135	45	135	8,9	6,4	5,4	4,3	3,7	3,2	2,8	5.53	0.33
80 T						19,4	13,3	10,8	8,6	7,3	6,4	5,7		
105 T						34,5	23,0	18,6	14,8	12,6	11,1	9,8		
130 T						97,7	66,1	53,4	42,4	36,2	31,7	28,0		
65 T		45	270	45	0	8,9	6,5	5,4	4,3	3,7	3,2	2,8	5.31	0.32
80 T						19,4	13,4	10,8	8,6	7,3	6,4	5,6		
105 T						34,5	23,0	18,5	14,7	12,6	11,0	9,7		
130 T						97,7	65,8	53,2	42,3	36,1	31,6	27,9		
65 T		60	120	60	120	8,9	6,0	4,8	3,8	3,3	2,9	2,5	5.53	0.25
80 T						19,4	11,9	9,6	7,6	6,5	5,7	5,0		
105 T						34,5	20,6	16,6	13,2	11,3	9,9	8,7		
130 T						97,7	59,4	48,2	38,3	32,7	28,6	25,2		
65 T		60	240	60	0	8,9	5,9	4,8	3,8	3,2	2,8	2,5	5.31	0.24
80 T						19,4	11,8	9,5	7,5	6,4	5,6	5,0		
105 T						34,5	20,5	16,5	13,1	11,2	9,8	8,7		
130 T						97,7	59,1	47,8	38,0	32,4	28,4	25,0		
65 T		90	90	90	90	8,9	5,1	4,1	3,3	2,8	2,5	2,2	5.53	0.16
80 T						19,4	10,2	8,2	6,5	5,6	4,9	4,3		
105 T						34,5	17,8	14,4	11,4	9,8	8,5	7,5		
130 T						97,7	51,9	41,9	33,3	28,4	24,9	21,9		
65 T		90	180	90	0	8,9	5,0	4,1	3,2	2,8	2,4	2,1	5.31	0.16
80 T						19,4	10,1	8,1	6,5	5,5	4,8	4,3		
105 T						34,5	17,5	14,1	11,2	9,6	8,4	7,4		
130 T						97,7	51,0	41,2	32,7	28,0	24,5	21,6		
65 T		120	60	120	60	8,9	4,6	3,7	3,0	2,5	2,2	2,0	5.53	0.12
80 T						19,4	9,3	7,5	6,0	5,1	4,5	4,0		
105 T						34,5	16,1	13,0	10,3	8,8	7,7	6,8		
130 T						97,7	47,0	38,0	30,2	25,8	22,6	19,9		
65 T		120	120	120	0	8,9	4,6	3,7	2,9	2,5	2,2	1,9	5.31	0.12
80 T						19,4	9,2	7,4	5,9	5,0	4,4	3,9		
105 T						34,5	15,8	12,8	10,1	8,7	7,6	6,7		
130 T						97,7	46,2	37,4	29,7	25,4	22,2	19,6		
65 T		150	30	150	30	8,9	4,3	3,5	2,8	2,4	2,1	1,8	5.53	0.10
80 T						19,4	8,8	7,1	5,7	4,8	4,2	3,7		
105 T						34,5	14,9	12,1	9,6	8,2	7,2	6,3		
130 T						97,7	43,7	35,3	28,1	24,0	21,0	18,5		
65 T		150	60	150	0	8,9	4,2	3,4	2,7	2,3	2,0	1,8	5.31	0.09
80 T						19,4	8,6	6,9	5,5	4,7	4,1	3,6		
105 T						34,5	14,6	11,8	9,4	8,0	7,0	6,2		
130 T						97,7	42,8	34,6	27,5	23,5	20,5	18,1		
65 T	180	0	180	0	8,9	4,1	3,3	2,6	2,2	2,0	1,7	5.53	0.08	
80 T					19,4	8,4	6,8	5,4	4,6	4,0	3,5			
105 T					34,5	14,0	11,3	9,0	7,7	6,7	5,9			
130 T					97,7	41,2	33,3	26,4	22,6	19,8	17,4			

SERIES	OSCILLATING DRIVE CODE				Static torque Ms [daN m]	Dynamic output torques Mu [daN m]						Accele- ration factor Ca	Input torque factor K	
	Angular stroke H° [deg]	PERIODS T° [deg] OF CYCLE				50	100	200	300	400	500			
		A motion	B dw ell	C motion		D dw ell	cycles/1'	cycles/1'	cycles/1'	cycles/1'	cycles/1'			cycles/1'
65 T	20	30	150	30	150	8,9	6,6	6,5	5,1	4,4	3,8	3,4	5.53	0.49
80 T						19,4	14,0	12,9	10,3	8,8	7,7	6,8		
105 T						34,5	25,7	21,9	17,4	14,9	13,0	11,5		
130 T						97,7	64,7	60,5	48,1	41,1	35,9	31,7		
65 T		30	300	30	0	8,9	6,6	6,6	5,2	4,5	3,9	3,4	5.31	0.47
80 T						19,4	14,1	13,1	10,4	8,9	7,8	6,9		
105 T						34,5	25,5	22,3	17,7	15,1	13,2	11,7		
130 T						97,7	64,4	61,2	48,7	41,6	36,3	32,1		
65 T		45	135	45	135	8,8	6,5	6,5	5,6	4,7	4,2	3,7	5.53	0.44
80 T						19,3	13,8	13,8	11,1	9,5	8,3	7,3		
105 T						34,2	26,9	24,1	19,2	16,4	14,3	12,6		
130 T						96,8	76,7	69,8	55,5	47,4	41,4	36,6		
65 T		45	270	45	0	8,8	6,6	6,6	5,5	4,7	4,1	3,6	5.31	0.42
80 T						19,3	14,0	13,8	11,0	9,4	8,2	7,2		
105 T						34,2	27,1	24,0	19,1	16,3	14,2	12,6		
130 T						96,8	79,4	69,8	55,4	47,4	41,4	36,6		
65 T		60	120	60	120	8,8	6,4	6,1	4,9	4,2	3,6	3,2	5.53	0.33
80 T						19,3	13,6	12,2	9,7	8,3	7,3	6,4		
105 T						34,2	26,3	21,3	16,9	14,5	12,6	11,1		
130 T						96,8	77,0	62,2	49,4	42,2	36,9	32,6		
65 T		60	240	60	0	8,8	6,3	6,1	4,8	4,1	3,6	3,2	5.31	0.32
80 T						19,3	13,4	12,1	9,6	8,2	7,2	6,3		
105 T						34,2	26,0	21,0	16,7	14,3	12,5	11,0		
130 T						96,8	76,1	61,5	48,9	41,7	36,5	32,2		
65 T		75	105	75	105	8,8	6,3	5,6	4,5	3,8	3,3	2,9	5.53	0.26
80 T						19,3	13,5	11,2	8,9	7,6	6,6	5,9		
105 T						34,2	24,2	19,5	15,5	13,3	11,6	10,2		
130 T						96,8	70,7	57,1	45,4	38,8	33,9	29,9		
65 T		75	210	75	0	8,8	6,1	5,5	4,4	3,8	3,3	2,9	5.31	0.25
80 T						19,3	12,9	11,0	8,8	7,5	6,5	5,8		
105 T						34,2	23,7	19,2	15,2	13,0	11,4	10,0		
130 T						96,8	69,5	56,1	44,6	38,1	33,3	29,4		
65 T		90	90	90	90	8,8	6,3	5,2	4,2	3,6	3,1	2,7	5.53	0.22
80 T						19,3	13,0	10,5	8,3	7,1	6,2	5,5		
105 T						34,2	22,5	18,2	14,4	12,3	10,8	9,5		
130 T						96,8	65,9	53,2	42,3	36,1	31,6	27,9		
65 T		90	180	90	0	8,8	5,9	5,1	4,1	3,5	3,1	2,7	5.31	0.21
80 T						19,3	12,6	10,3	8,2	7,0	6,1	5,4		
105 T						34,2	22,1	17,8	14,2	12,1	10,6	9,3		
130 T						96,8	64,7	52,2	41,5	35,5	31,0	27,4		
65 T		120	60	120	60	8,8	5,9	4,8	3,8	3,2	2,8	2,5	5.53	0.16
80 T						19,3	12,0	9,7	7,7	6,6	5,7	5,1		
105 T						34,2	20,2	16,3	13,0	11,1	9,7	8,6		
130 T						96,8	59,3	47,9	38,1	32,5	28,5	25,1		
65 T		120	120	120	0	8,8	5,8	4,7	3,7	3,2	2,8	2,5	5.31	0.16
80 T						19,3	11,7	9,4	7,5	6,4	5,6	4,9		
105 T						34,2	19,9	16,0	12,7	10,9	9,5	8,4		
130 T						96,8	58,2	47,0	37,4	31,9	27,9	24,6		
65 T	150	30	150	30	8,8	5,5	4,5	3,5	3,0	2,7	2,3	5.53	0.13	
80 T					19,3	11,3	9,1	7,2	6,2	5,4	4,8			
105 T					34,2	18,7	15,1	12,0	10,3	9,0	7,9			
130 T					96,8	54,9	44,4	35,2	30,1	26,3	23,2			
65 T	150	60	150	0	8,8	5,4	4,4	3,5	3,0	2,6	2,3	5.31	0.13	
80 T					19,3	10,9	8,8	7,0	6,0	5,2	4,6			
105 T					34,2	18,3	14,8	11,8	10,1	8,8	7,8			
130 T					96,8	53,7	43,4	34,5	29,5	25,8	22,7			
65 T	180	0	180	0	8,8	5,2	4,2	3,4	2,9	2,5	2,2	5.53	0.11	
80 T					19,3	10,8	8,7	6,9	5,9	5,2	4,6			
105 T					34,2	17,6	14,2	11,3	9,6	8,4	7,4			
130 T					96,8	51,6	41,7	33,1	28,3	24,8	21,8			



SERIES	OSCILLATING DRIVE CODE				Static torque Ms [daN m]	Dynamic output torques Mu [daN m]						Acceler- ation factor Ca	Input torque factor K	
	Angular stroke H° [deg]	PERIODS T° [deg] OF CYCLE				50	100	200	300	400	500			
		A motion	B dw ell	C motion		D dw ell	cycles/1'	cycles/1'	cycles/1'	cycles/1'	cycles/1'			cycles/1'
65 T	30	30	150	30	150	8,9	6,6	6,5	5,1	4,4	3,8	3,4	5.53	0.49
80 T						19,4	14,0	12,9	10,3	8,8	7,7	6,8		
105 T						34,5	25,7	21,9	17,4	14,9	13,0	11,5		
130 T						97,7	64,7	60,5	48,1	41,1	35,9	31,7		
65 T		30	300	30	0	8,9	6,6	6,6	5,2	4,5	3,9	3,4	5.31	0.47
80 T						19,4	14,1	13,1	10,4	8,9	7,8	6,9		
105 T						34,5	25,5	22,3	17,7	15,1	13,2	11,7		
130 T						97,7	64,4	61,2	48,7	41,6	36,3	32,1		
65 T		45	135	45	135	8,7	6,6	6,6	6,6	5,8	5,1	4,5	5.53	0.66
80 T						18,9	14,1	14,1	13,5	11,6	10,1	8,9		
105 T						33,4	27,5	27,3	23,5	20,0	17,5	15,5		
130 T						94,2	80,4	80,0	68,5	58,6	51,2	45,2		
65 T		45	270	45	0	8,7	6,7	6,7	6,3	5,4	4,7	4,2	5.31	0.63
80 T						18,9	14,3	14,3	12,6	10,7	9,4	8,3		
105 T						33,4	27,8	27,4	21,8	18,6	16,3	14,4		
130 T						94,2	81,2	80,2	63,7	54,4	47,6	42,0		
65 T		60	120	60	120	8,7	6,5	6,5	5,2	4,4	3,9	3,4	5.53	0.49
80 T						18,9	13,8	13,0	10,3	8,8	7,7	6,8		
105 T						33,4	26,9	22,6	17,9	15,3	13,4	11,8		
130 T						94,2	78,6	65,9	52,4	44,8	39,2	34,5		
65 T		60	240	60	0	8,7	6,4	6,3	5,1	4,4	3,8	3,4	5.31	0.47
80 T						18,9	13,5	12,8	10,1	8,7	7,6	6,7		
105 T						33,4	26,3	22,2	17,6	15,1	13,2	11,6		
130 T						94,2	77,1	64,9	51,6	44,1	38,5	34,0		
65 T		75	105	75	105	8,7	6,4	5,9	4,7	4,0	3,5	3,1	5.53	0.39
80 T						18,9	13,6	11,8	9,4	8,0	7,0	6,2		
105 T						33,4	25,4	20,5	16,3	13,9	12,2	10,7		
130 T						94,2	74,3	60,0	47,7	40,7	35,6	31,4		
65 T		75	210	75	0	8,7	6,1	5,8	4,6	3,9	3,4	3,0	5.31	0.38
80 T						18,9	13,1	11,6	9,2	7,9	6,9	6,1		
105 T						33,4	24,8	20,1	15,9	13,6	11,9	10,5		
130 T						94,2	72,7	58,7	46,7	39,9	34,9	30,8		
65 T		90	90	90	90	8,7	6,4	5,5	4,4	3,8	3,3	2,9	5.53	0.33
80 T						18,9	13,5	11,1	8,8	7,6	6,6	5,8		
105 T						33,4	23,4	18,9	15,0	12,9	11,2	9,9		
130 T						94,2	68,7	55,5	44,1	37,7	32,9	29,1		
65 T		90	180	90	0	8,7	6,0	5,4	4,3	3,7	3,2	2,8	5.31	0.32
80 T						18,9	12,7	10,9	8,6	7,4	6,5	5,7		
105 T						33,4	23,0	18,5	14,7	12,6	11,0	9,7		
130 T						94,2	67,3	54,3	43,2	36,9	32,3	28,5		
65 T		120	60	120	60	8,7	6,3	5,1	4,0	3,4	3,0	2,7	5.53	0.25
80 T						18,9	12,7	10,3	8,2	7,0	6,1	5,4		
105 T						33,4	21,0	16,9	13,5	11,5	10,1	8,9		
130 T						94,2	61,4	49,6	39,4	33,7	29,4	26,0		
65 T		120	120	120	0	8,7	5,8	4,9	3,9	3,4	2,9	2,6	5.31	0.24
80 T						18,9	12,3	10,0	7,9	6,8	5,9	5,2		
105 T						33,4	20,6	16,6	13,2	11,3	9,9	8,7		
130 T						94,2	60,2	48,6	38,6	33,0	28,9	25,5		
65 T	150	30	150	30	8,7	5,9	4,8	3,8	3,2	2,8	2,5	5.53	0.20	
80 T					18,9	12,0	9,7	7,7	6,6	5,8	5,1			
105 T					33,4	19,2	15,7	12,5	10,7	9,3	8,2			
130 T					94,2	56,6	45,7	36,3	31,0	27,1	23,9			
65 T	150	60	150	0	8,7	5,7	4,6	3,7	3,1	2,7	2,4	5.31	0.19	
80 T					18,9	11,5	9,3	7,4	6,3	5,5	4,9			
105 T					33,4	19,0	15,4	12,2	10,4	9,1	8,1			
130 T					94,2	55,4	44,7	35,5	30,4	26,5	23,4			
65 T	180	0	180	0	8,7	5,6	4,5	3,6	3,1	2,7	2,4	5.53	0.16	
80 T					18,9	11,4	9,2	7,4	6,3	5,5	4,8			
105 T					33,4	18,3	14,8	11,7	10,0	8,8	7,7			
130 T					94,2	53,1	42,9	34,1	29,1	25,4	22,4			



SERIES	OSCILLATING DRIVE CODE				Static torque Ms [daN m]	Dynamic output torques Mu [daN m]						Acceler- ation factor Ca	Input torque factor K	
	Angular stroke H° [deg]	PERIODS T° [deg] OF CYCLE				50	100	200	300	400	500			
		A motion	B dw ell	C motion		D dw ell	cycles/1'	cycles/1'	cycles/1'	cycles/1'	cycles/1'			cycles/1'
65 T	45	45	135	45	135	8,8	6,5	6,5	5,6	4,7	4,2	3,7	5.53	0.44
80 T						19,3	13,8	13,8	11,1	9,5	8,3	7,3		
105 T						34,2	26,9	24,1	19,2	16,4	14,3	12,6		
130 T						96,8	76,7	69,8	55,5	47,4	41,4	36,6		
65 T		45	270	45	0	8,8	6,6	6,6	5,5	4,7	4,1	3,6	5.31	0.42
80 T						19,3	14,0	13,8	11,0	9,4	8,2	7,2		
105 T						34,2	27,1	24,0	19,1	16,3	14,2	12,6		
130 T						96,8	79,4	69,8	55,4	47,4	41,4	36,6		
65 T		60	120	60	120	8,3	6,6	6,6	6,4	6,0	5,6	4,9	5.53	0.74
80 T						18,0	14,2	14,1	14,0	12,7	11,1	9,8		
105 T						31,4	27,5	27,3	25,8	22,0	19,3	17,0		
130 T						88,1	80,4	80,1	75,4	64,4	56,3	49,7		
65 T		60	240	60	0	8,3	6,5	6,4	6,3	5,8	5,1	4,5	5.31	0.71
80 T						18,0	13,8	13,7	13,2	11,7	10,2	9,0		
105 T						31,4	26,8	26,5	23,7	20,2	17,7	15,6		
130 T						88,1	78,5	77,7	69,3	59,2	51,8	45,7		
65 T		75	105	75	105	8,3	6,5	6,5	5,9	5,1	4,4	3,9	5.53	0.59
80 T						18,0	13,9	13,9	11,8	10,1	8,8	7,8		
105 T						31,4	27,0	25,7	20,4	17,5	15,3	13,5		
130 T						88,1	79,1	75,2	59,7	51,0	44,6	39,4		
65 T		75	210	75	0	8,3	6,2	6,2	5,6	4,7	4,2	3,7	5.31	0.57
80 T						18,0	13,2	13,1	11,2	9,5	8,3	7,4		
105 T						31,4	25,7	24,1	19,2	16,4	14,3	12,6		
130 T						88,1	75,4	70,5	56,0	47,9	41,9	36,9		
65 T		90	90	90	90	8,3	6,4	6,4	5,3	4,5	3,9	3,5	5.53	0.49
80 T						18,0	13,7	13,4	10,7	9,1	8,0	7,0		
105 T						31,4	26,7	22,5	17,9	15,3	13,4	11,8		
130 T						88,1	78,2	65,6	52,2	44,6	39,0	34,4		
65 T		90	180	90	0	8,3	6,1	6,0	5,1	4,4	3,8	3,4	5.31	0.47
80 T						18,0	12,9	12,8	10,3	8,8	7,7	6,8		
105 T						31,4	25,1	22,0	17,5	14,9	13,1	11,5		
130 T						88,1	73,4	64,1	50,9	43,5	38,0	33,6		
65 T		120	60	120	60	8,3	6,4	6,1	4,9	4,2	3,6	3,2	5.53	0.37
80 T						18,0	13,5	12,4	9,9	8,4	7,4	6,5		
105 T						31,4	25,1	20,2	16,1	13,7	12,0	10,6		
130 T						88,1	72,3	58,4	46,4	39,7	34,7	30,6		
65 T		120	120	120	0	8,3	5,9	5,8	4,7	4,0	3,5	3,1	5.31	0.36
80 T						18,0	12,5	11,9	9,5	8,1	7,1	6,2		
105 T						31,4	24,4	19,8	15,7	13,4	11,7	10,4		
130 T						88,1	71,0	57,4	45,6	39,0	34,1	30,1		
65 T		150	30	150	30	8,3	6,3	5,8	4,6	3,9	3,4	3,0	5.53	0.30
80 T						18,0	13,4	11,7	9,3	8,0	7,0	6,2		
105 T						31,4	23,4	18,9	15,0	12,8	11,2	9,9		
130 T						88,1	67,2	54,3	43,2	36,9	32,2	28,5		
65 T		150	60	150	0	8,3	5,8	5,5	4,4	3,7	3,3	2,9	5.31	0.28
80 T						18,0	12,2	11,1	8,8	7,5	6,6	5,8		
105 T						31,4	22,7	18,3	14,6	12,4	10,9	9,6		
130 T						88,1	65,5	52,9	42,0	35,9	31,4	27,7		
65 T	180	0	180	0	8,3	6,3	5,5	4,4	3,7	3,3	2,9	5.53	0.25	
80 T					18,0	13,3	11,2	8,9	7,6	6,6	5,8			
105 T					31,4	22,2	17,9	14,2	12,2	10,6	9,4			
130 T					88,1	63,3	51,2	40,7	34,7	30,4	26,8			

6. SIZING OF THE TANDEM MECHANISM

In order to calculate the size of a TANDEM CF3 mechanism, one must calculate first of all the sizes of the two internal mechanisms separately, by determining the highest torques required on output shafts “1” and “2”. It can occur that a different size can derive from the two mechanisms considered; the correct choice of the tandem CF3 size to apply, is to be made using the largest of the mechanisms calculated.

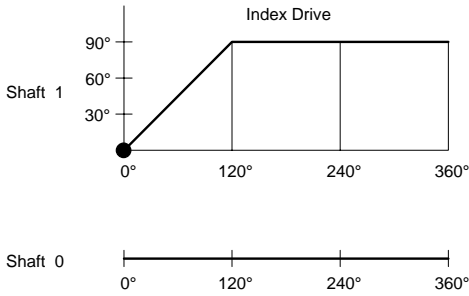

Fig. 14

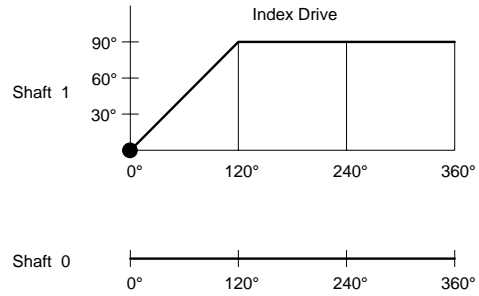

Fig. 15

6.1 Input torque required - Ma

a) If the movements of output shafts “1” and “2” are executed one after the other, the maximum torque required at input shaft “ø” will be equivalent to the higher of the input torques required by the separate mechanisms.

b) If the movements of output shafts “1” and “2” are executed simultaneously, the maximum torque required at input shaft “ø” will be equivalent to the sum of the input torques required by the separate mechanisms.

If the required input torques are, for the shaft n° 1, $Ma1 = 7,68$ [daN·m], for the shaft n° 2, $Ma2 = 0.232$ [daN·m], we will have:

Event a) $Ma = \text{the higher of } Ma1 \text{ and } Ma2;$ $Ma = Ma1 = 7.68$ [daN·m]

Event b) $Ma = Ma1 + Ma2;$ $Ma = 7.68 + 0.232 = 7.912$ [daN·m]

6.2 Input power required - P

a) If the movements of output shafts “1” and “2” are executed one after the other, the maximum power required at input shaft “ø” will be equivalent to the higher of the powers required by the separate mechanisms.

b) If the movements of output shafts “1” and “2” are executed simultaneously, the maximum power required at input shaft “ø” will be equivalent to the sum of the powers required by the separate mechanisms

If the required input powers are, for the shaft n° 1, $P1 = 0,98$ [kW], for the shaft n° 2, $P2 = 0.03$ [kW], we will have:

Event a) $P = \text{the higher of } P1 \text{ and } P2;$ $P = P1 = 0.98$ [kW]

Event b) $P = P1 + P2;$ $P = 0.98 + 0.03 = 1.01$ [kW]



7. ASSEMBLY

The different combinations of the movements which can be executed at the TANDEM CF3 output shafts and the sequence in which these movements shall be executed require an accurate definition of the assemblies, that is to say, of the directions of rotation of the shafts and of the synchronization between the cycles of the two output motions.

In order to define the TANDEM CF3 assemblies unequivocally, the following conditions must be complied with:

- 1) The TANDEM CF3 is viewed from side "B", with side "E" - on which the worm screw shaft can be mounted - to the left, regardless of whether side "B" contains the input shaft "0" or output shafts "1" and "2".
- 2) The output shaft "1" is always the shaft to the left of the figure, next to side "E". The output shaft "2" is always to the right, next to side "C"
- 3) The assembly code must always be indicated when designating each of the output shafts. This code consists of two letters, the first designating the direction of rotation of the input shaft, and there is therefore only one for both designations, and the second designating the direction of rotation of the output shaft. The direction of rotation is indicated with the letter "D" if it is clockwise and with the letter "S" if it is counterclockwise.

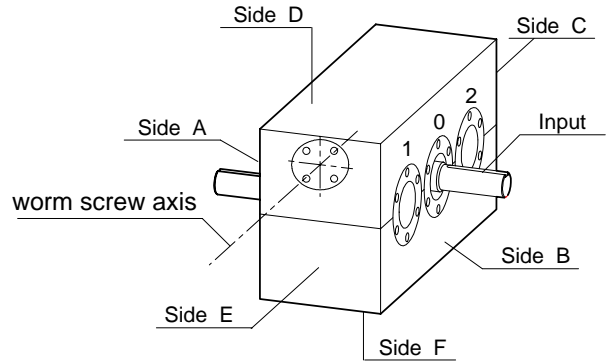

Fig. 16

The possible assemblies are represented as follows:

On the INDEX DRIVE: since the output shaft always turns in the opposite direction to the input shaft, we will have the following possibilities according as the indexing motion is applied to shaft "1" or shaft "2":

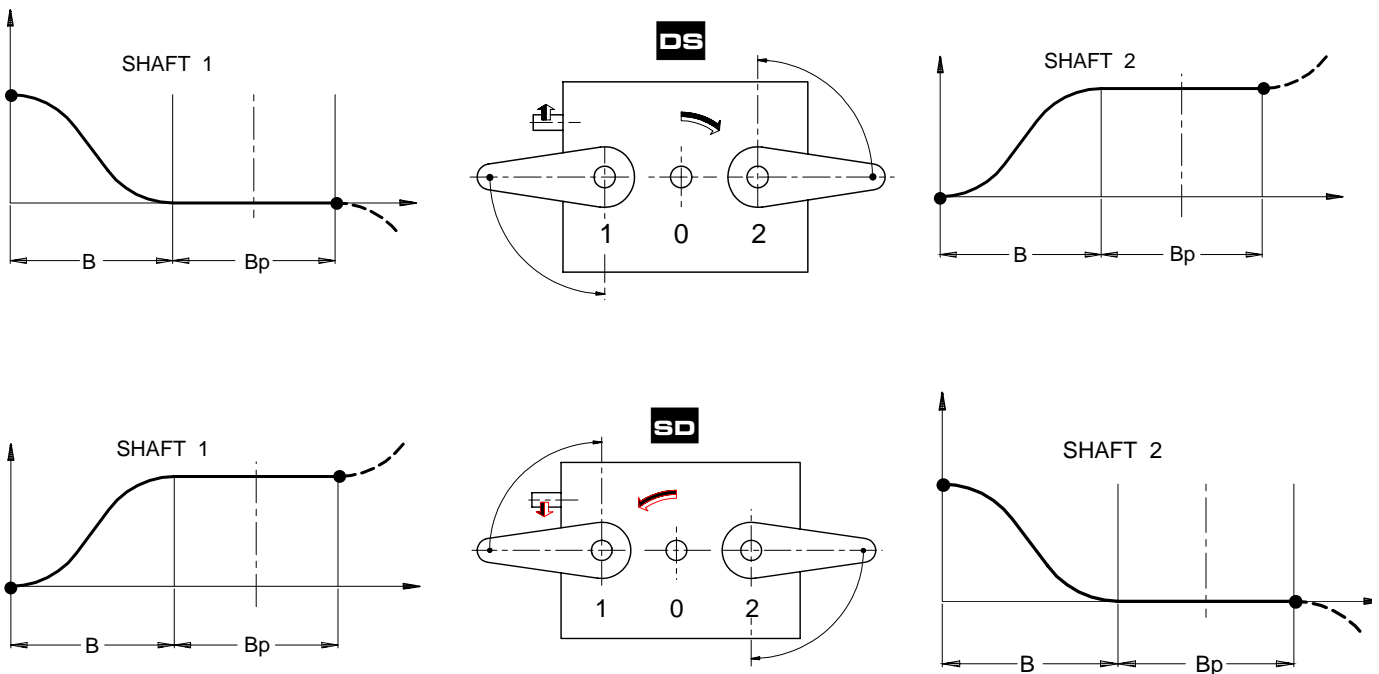

Fig. 17

On the OSCILLATING DRIVE: since the direction of rotation of the output shaft does not depend on that of the input shaft, and only the direction of motion during the displacement time "A" of the cycle is considered, we will have the following possibilities according as the oscillating motion is applied to shaft "1" or shaft "2":

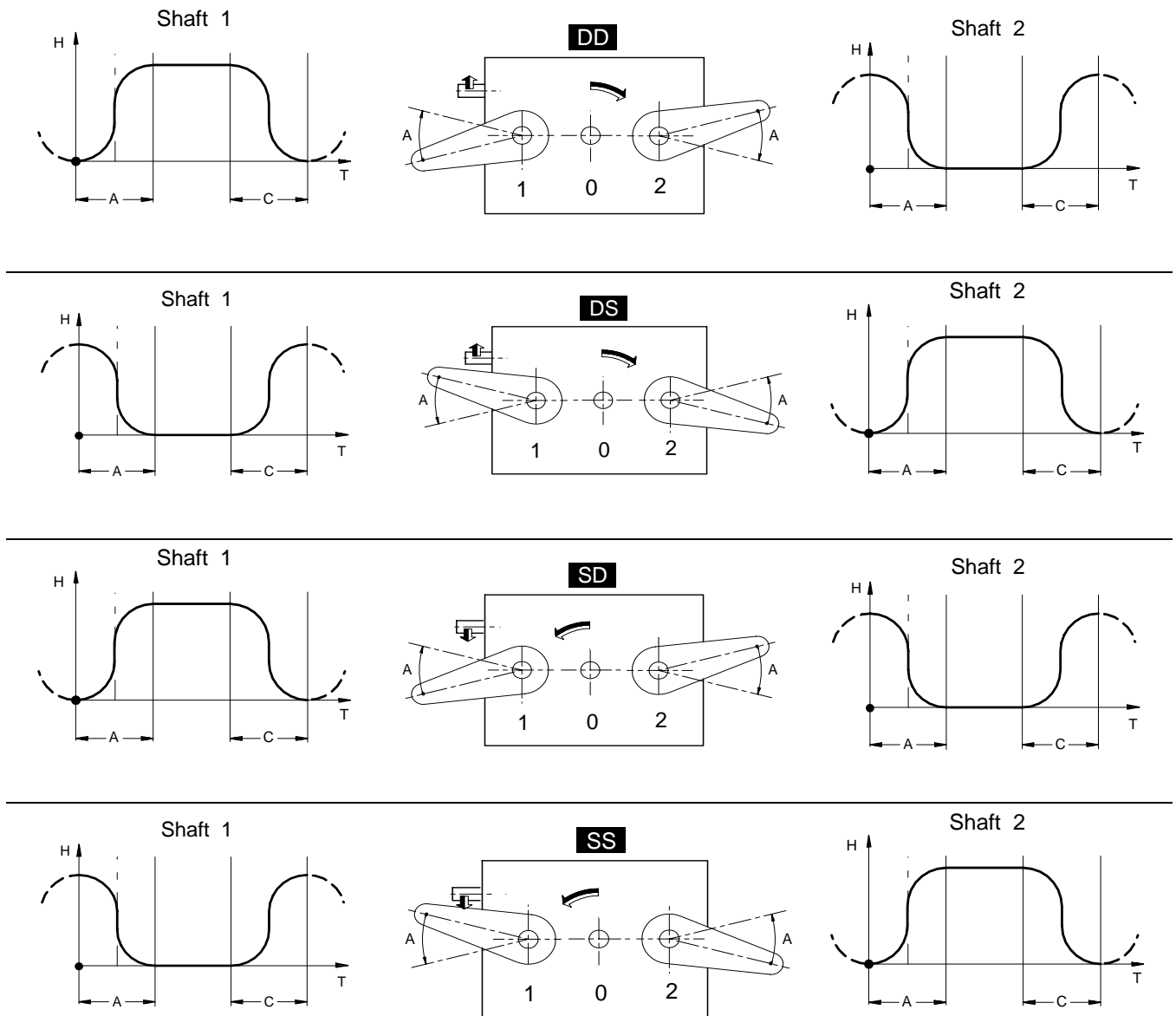

Fig. 18

The internal worm screw reduction gear has a right-hand helix, so that any screw shaft rotation depends on the direction of rotation of shaft "Ø", as shown in the preceding assembly diagrams.

8. SYNCHRONIZATION (PHASE SETTING)

In order to define correctly the synchronizations of the motions and the position of the feathers of the input shaft "Ø" and of the output shafts "1" and "2", the following conditions must be observed:

- 1) The mechanism which originates the cycle of the two motions is always the one which actuates shaft "1"(primary), while the mechanism which actuates shaft "2" must always be considered subordinate to the first (secondary). Synchronization is obtained by determining, on input shaft "Ø", the angular distance expressed in degrees between the cycle start point of the mechanism which actuates shaft "1" and the cycle start point of the mechanism which actuates shaft "2". This synchronization is called "PHASE ANGLE" and indicated with the letters "AF". In order to determine it accurately, it is useful and necessary to draw time-displacement charts of the two motions on the same abscissa scale as shown in fig. 19.
- 2) On the "TANDEM CF3" drive, the position of the feathers of the different shafts, as shown on figure 20, is obtained under the following conditions.

8.1 SHAFT Ø

The position of the feather of shaft Ø is always referred to the cycle of movements of the primary mechanism, which is the one which actuates shaft "1".

If shaft "1" is actuated by an indexing drive, the feather of shaft Ø will be in the position indicated when we are half-way through the dwell period "Bp" (fig. 11).

If shaft "1" is actuated by an oscillating drive, the feather of shaft Ø will be in the position indicated when we are half-way through the motion period "A" (fig. 13).

In the secondary mechanism which actuates shaft "2", the position of the feather of shaft Ø will depend on the phase angle between the cycles of the two drives.

8.2 SHAFTS "1" e "2"

The feathers of shafts "1" and "2" are referred to the type of mechanism which actuates them as follows:

If the shaft we are considering turns with indexing motion, the feathers are in the positions shown when the shaft is halted at one of the stations.

If the shaft we are considering turns with oscillating motion, the feathers are in the positions shown when the shaft is half-way through oscillation H°.

By reversing the direction of rotation of the input shaft, the direction of progress of the times-displacements charts of both mechanisms is reversed. Practically, the direction of the chart proceeds from right to left and the position of the phase angle between the two movements remains unchanged.

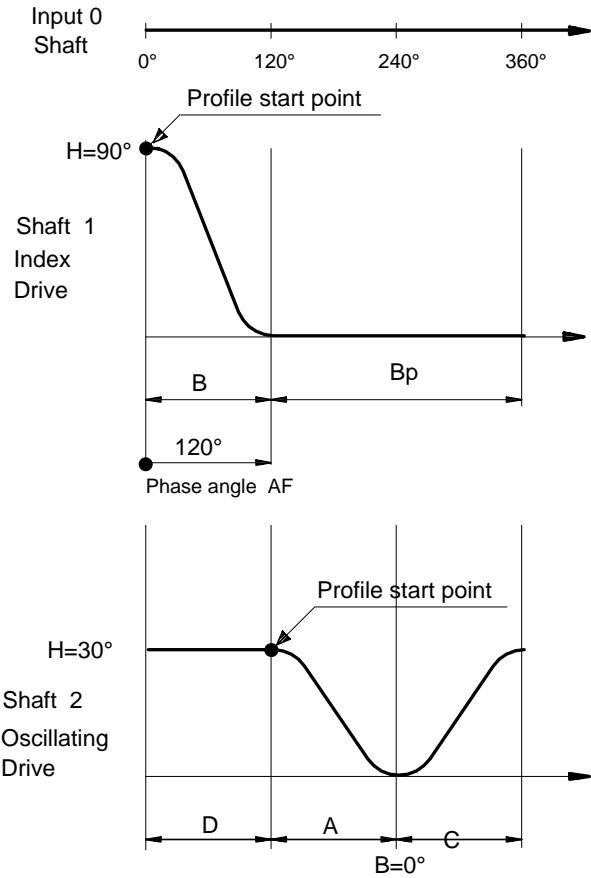

Fig. 19 - Times-displacements charts of the INDEX DRIVE and of the OSCILLATING DRIVE in the examples of calculation and example of designation.

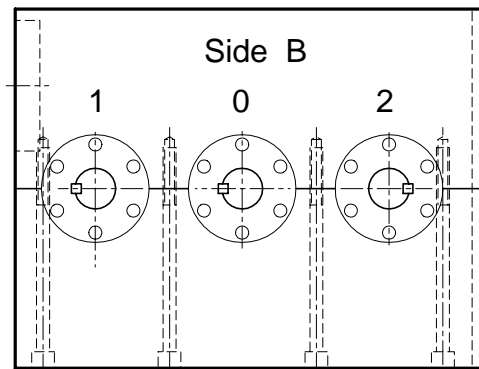

Fig. 20 - Representation of the positions of shafts "0", "1" and "2".

9. VERSIONS

TANDEM CF3 mechanisms are suitable for many other types of motor-driven arrangements, such as speed change gear units, brake-clutch units, etc. Please contact us for any information or explanations. We are at your disposal to suggest the most suitable solution to solve your specific problem.

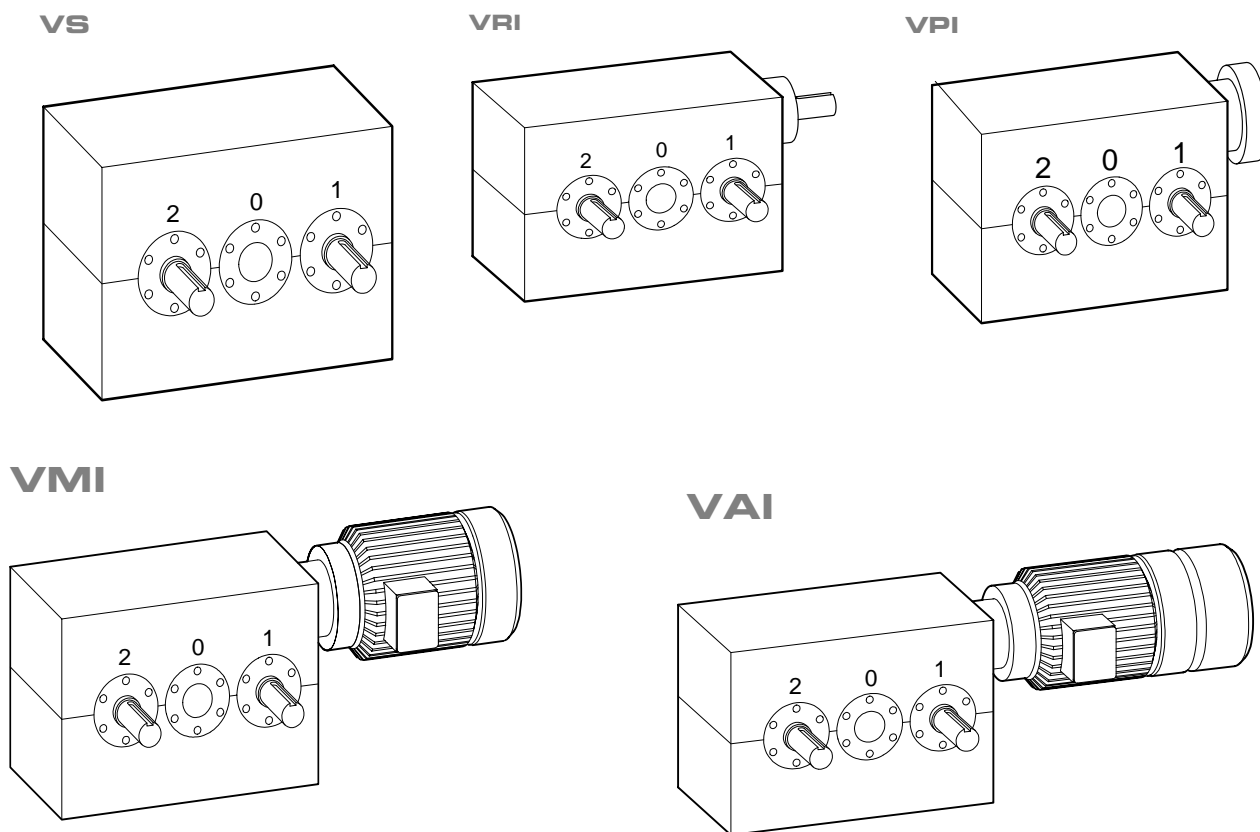

Fig. 21

- VS = Standard unit
- VRI = Unit with built in reduction gear
- VPI = Unit with built in reduction gear pre-disposed for motor coupling
- VMI = Unit with built in reduction gear and motor
- VAI = Unit with built in reduction gear and brake motor

10. MOUNTING POSITIONS

- 0 Side with input shaft "0"
- 1 Side with output shaft "1"
- 2 Side with output shaft "2"
- 3 Side with oil plugs
- 4 Bottom side after mounting

	A	B	C	D	E	F
0	■	■				
1	■	■				
2	■	■				
3			■	■		■
4	■	■	■	■	■	■

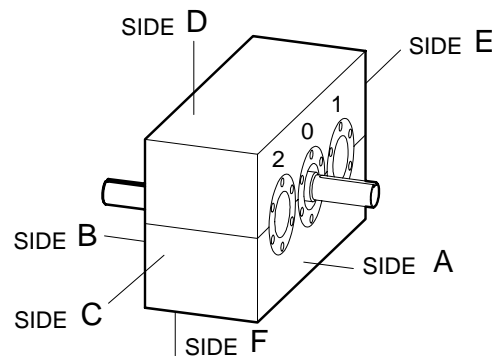

Fig.22

11. DESIGNATION

The designation of the “TANDEM CF3” mechanism consists of an alphanumeric combination based on the chart below. When ordering, please refer to this chart to avoid misunderstandings or delays in delivery.

• **Designation of the size, version and mounting positions.**

TANDEM CF3	<input type="text" value="T"/>	<input type="text" value="0"/>	<input type="text" value="1"/>	<input type="text" value="2"/>	<input type="text" value="3"/>	<input type="text" value="4"/>	<input type="text"/>
Series _____							
Version _____							
0 side with input shaft _____							
1 side with output shaft 1 _____							
2 side with output shaft 2 _____							
3 side with oil filling plugs (add "LV" for long-life lubrication) _____							
4 bottom side after mounting _____							
Worm screw reduction gear ratio (do not indicate for version VSS) _____							

N.B. The holes for the oil filling plugs are not provided in case of “long life” lubrication (see pag. 25).

• **Shaft “1” mechanism**

SHAFT 1	Oscillating Drive <input type="text"/>	<input type="text"/>	<input type="text"/>
	Index Drive <input type="text"/>	<input type="text"/>	<input type="text"/>
Angle of oscillation / stations _____			
Cycle times / Displacement angle _____			
Assembly _____			

• **Shaft “2” mechanism**

SHAFT 2	Oscillating Drive <input type="text"/>	<input type="text"/>	<input type="text"/>	<input type="text" value="AF"/>
	Index Drive <input type="text"/>	<input type="text"/>	<input type="text"/>	
Angle of oscillation / stations _____				
Cycle times / Displacement angle _____				
Assembly _____				
Phase angle _____				

• **Motor drive**

MOTOR	<input type="text"/>	<input type="text" value="kW"/>	<input type="text" value="P"/>	<input type="text" value="V"/>	<input type="text" value="Hz"/>
Size and version _____					
Power _____					
No. of poles _____					
Voltage [V] _____					
Frequency _____					

N.B. List any other special characteristics of the motor drive. On version “VSP” indicate only the size and version of the motor, disregarding polarity, voltage, frequency.

Example of designation

- TANDEM CF3 series 105 T mechanism with worm screw reduction gear ratio 1:31. Mounting positions: input shaft “0” on side A, output shaft “1” on side B, output shaft “2” on side B, long-life lubrication, bottom side after mounting F.
- Indexing drive on shaft “1”: 4 stations, indexing angle 120°, assembly DS.
- Oscillating drive on shaft “2” oscillating angle 30°, cycle periods 120/0/120/120, assembly DD, phase angle 120°.

Designation for the order:

TANDEM CF3 105T-VRI-0A-1B-2B-3LV-4F - 1:31
Shaft 1 4-120-DS
Shaft 2 30°-120/0/120/120-DD-AF120



12. OVERALL DIMENSIONS

Version VS

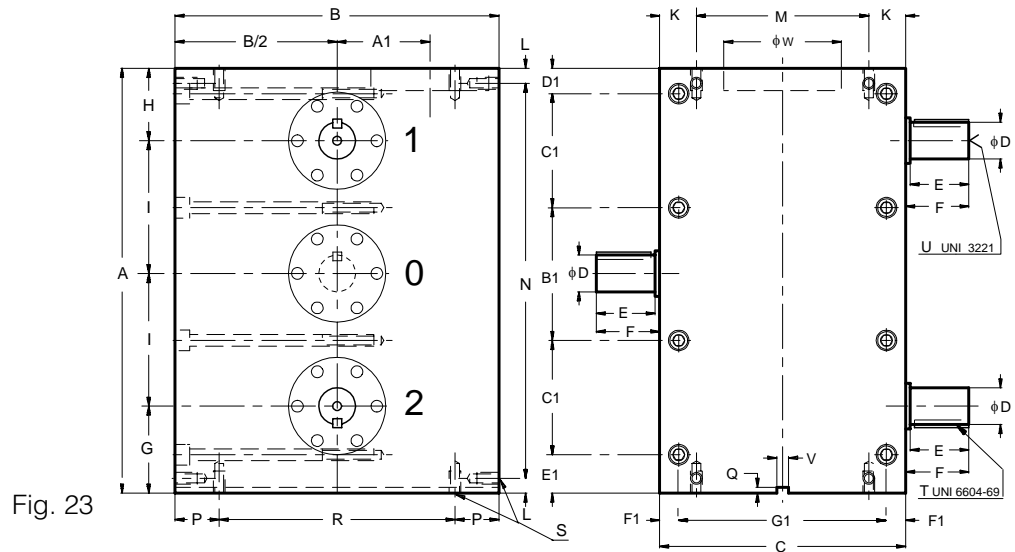

SERIES	A	B	C	Ø D _{k6}	E	F	G	H	I	K	L	M	N	P
65 T	288	220	167	19	40	43	59	49	90	25	10	117	268	30
80 T	370	280	214	28	60	65	80	70	110	12.5	12.5	189	345	30
105 T	520	360	284	30	80	85	130	100	145	17.5	17.5	249	485	35
130 T	630	470	345	42	110	115	140	120	185	18	18	309	594	40

SERIES	Q	R	S	T	U	V ^P ₉	ØW ^H ₇	A ₁	B ₁	C ₁	D ₁	E ₁	F ₁	G ₁	Weight ~ Kg
65 T	4	160	M 8x15	6x6x 35	M 6x16	8	78	63	90	77,5	17	26	13	141	50
80 T	-	220	M 8x15	8x7x 55	M10x22	-	110	80	110	95	30	40	18	178	90
105 T	-	290	M10x20	8x7x 75	M10x22	-	130	100	145	125	47,5	77,5	20	244	190
130 T	-	390	M12x25	12x8x100	M16x36	-	160	140	185	157,5	55	75	18	309	340

Version VRI

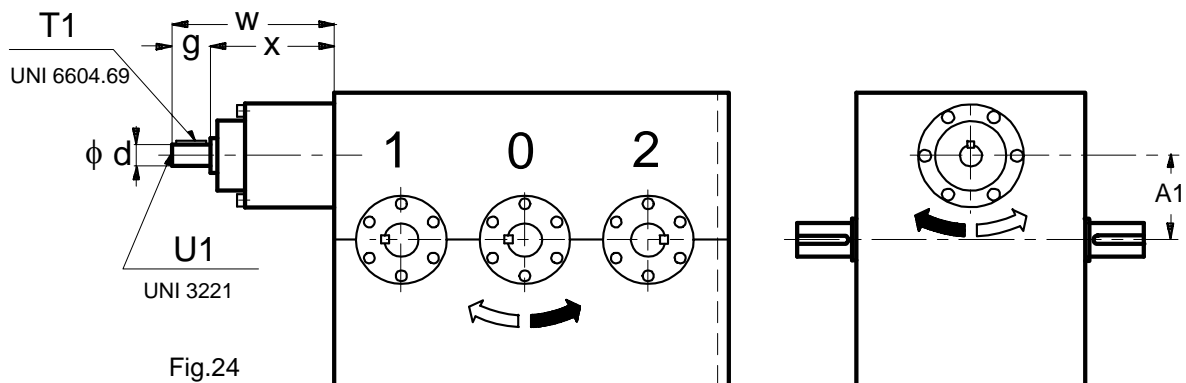

SERIES	A ₁	d ^{k6}	U ₁	g	T ₁	x	w	REDUCTION RATIOS								
								1:6	1:12	--	1:19	1:26	1:34	1:48	1:63	1:70
65 T	63	16	M5x12,5	28	5x5x25	90	118	1:6	1:12	--	1:19	1:26	1:34	1:48	1:63	1:70
80 T	80	19	M6x16	28	6x6x25	98	126	1:6.75	1:12	--	1:20	--	1:30	--	1:50	1:80
105 T	100	28	M10x22	42	8x7x36	93	135	1:6.25	1:10.33	1:15.5	1:20.5	1:24.5	1:31	1:41	1:50	--
130 T	140	38	M12x28	58	10x8x50	77	135	--	1:10.33	1:15.5	1:19.5	1:25.5	1:31	1:39	1:51	--

Versions VPI
 Versions VMI
 Versions VAI

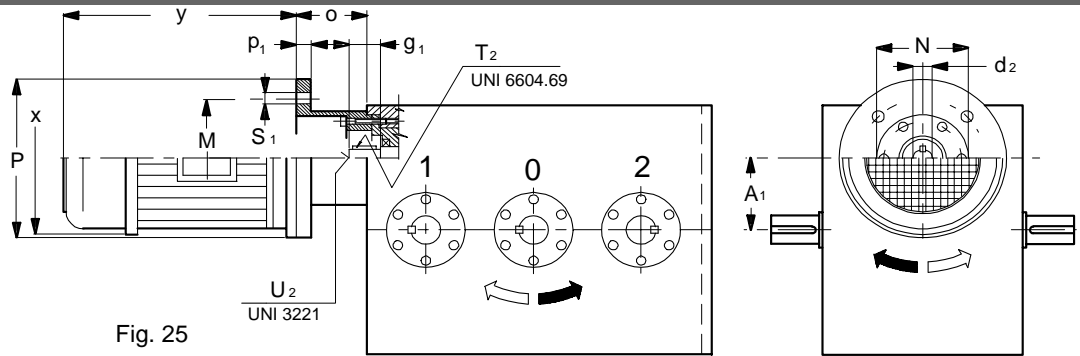

Fig. 25

Series	A ₁	d ₂ ^{K6}	g ₁	O	P	T ₂	U ₂	Prov. for coupling the Motor ¹⁾					MOTOR - 4 POLES			
								IEC 72 (71)	N	M	P	S ₁	Grad. IEC 72	Standard x y	Self-Brakg x y	
65 T	63	16	26	59	10	5x5x18	M5x12,5	C120	80	100	120	6,6	80	156 231	160 290	
				C160				110	130	160	9	90s 176 251	180 315			
												90L 176 275	180 334			
80 T	80	20	35	51	12	6x6x30	M6x16	C160	110	130	160	9	80	156 231	160 290	
				90s									176 251	180 315		
				90L									176 275	180 334		
				100M									194 306	196 363		
105 T	100	28	35	48	15	8x7x30	M10x22	A200	130	165	200	M10	90s	176 251	180 315	
				90L									176 275	180 334		
				100									194 306	196 363		
				112M									224 329	220 403		
				132s									263 350	260 442		
130 T	140	38	42	39	20	10x8x38	M12x28	A250	180	215	250	M12	100	194 306	196 363	
				112M									224 329	220 403		
				132s									263 350	260 442		
				132M									263 388	260 480		
				160M									315 501	315 630		
				160L									315 544	315 674		
				180M									353 545	353 --		
				180L									353 580	353 730		

¹⁾ Motor coupling flanges to IEC 72 (1971) and DIN 42677 part 1 standards - The letter C indicates the form B14 - Letter A indicates the form B5.

POSITION OF THE OIL FILLING HOLES

If oil filling plugs are required, they are all positioned diagonally on one of the sides (C-D-F) of the box. Any positions of the oil filling plugs which are different from those indicated in this catalogue are optional and must be ordered by the customer with a dimensioned drawing.

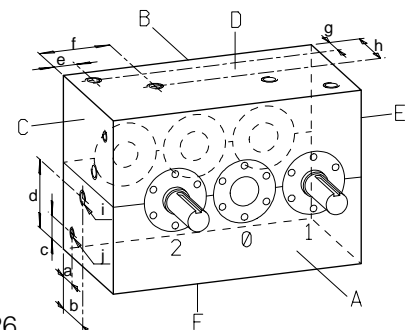

FIG. 26

SERIES	a	b	c	d	e	f	g	h	i	j	Oil quantity Kg
65 T	40	65	15	95	28	132	40	72	R 1/4"	R 1/4"	~ 4
80 T	42	98	15	128	28	173	42	95	R 3/8"	R 1/4"	~ 8
105 T	47	133	16	168	40	248	47	130	R 3/8"	R 1/4"	~ 20
130 T	50	163	18	223	45	303	50	160	R 3/8"	R 1/4"	~ 45



13. APPLICATION EXAMPLES OF TANDEM CF3

13.1 Lifting and handling equipment

The picture shows lifting and handling equipment driven by a “TANDEM CF3” mechanism where the horizontal movement is obtained by means of a two-station indexing drive and a connecting rod and crank transmission; the vertical movement is obtained by means of a two-station indexing drive with speed slowing for impact-free lifting and resting of the workpiece and of a connecting rod and crank transmission.

The movements are controlled by the general machine motor drive, which actuates the input shaft of the TANDEM CF3 mechanism directly with a 1:1 ratio, assuring mechanical synchronism of all movements.

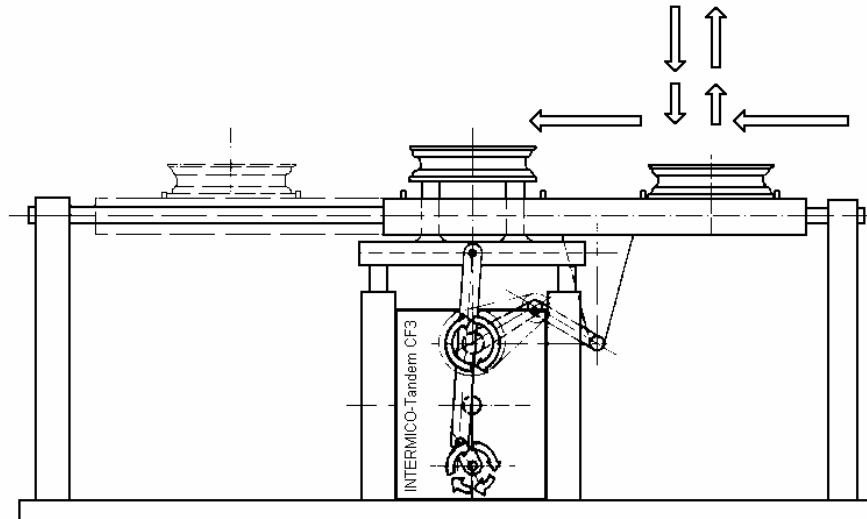

Fig. 27

13.2 Lifting and handling equipment

The picture shows lifting and handling equipment driven by a “TANDEM CF3” mechanism where the horizontal movement is obtained by means of a two-station indexing drive and transmission via a linked system; the vertical movement is obtained by means of an oscillating drive and a linkage consisting of two coupled transmissions.

The movements obtained by means of a self-braking electric motor provide electric synchronizing of the “TANDEM CF3” mechanism movements with the machine movements.

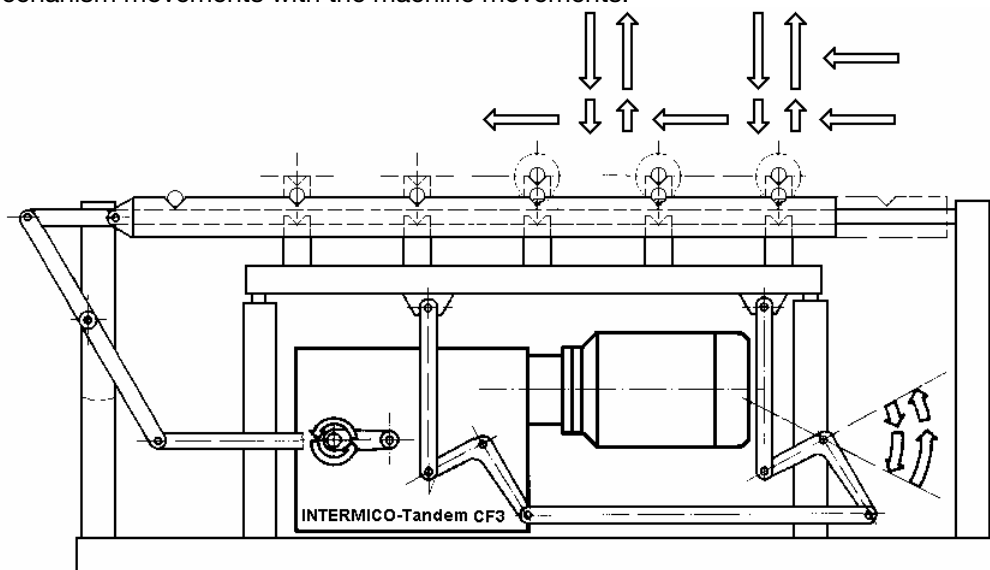

Fig. 28

13.3 Linear manipulator

The manipulator assembly in the picture belongs to our standard range and is actuated by a TANDEM CF3 drive. The extended gripper travel is obtained by means of a 2-station indexing drive and a connecting rod-crank transmission; the gripper's upward and downward motion are obtained by means of an oscillating drive and a lever. The linear traversing unit supports mechanical grippers which open and close through the action of a cam on the input shaft. All movements are mechanically synchronized. The manipulator is powered by a self-braking motor.

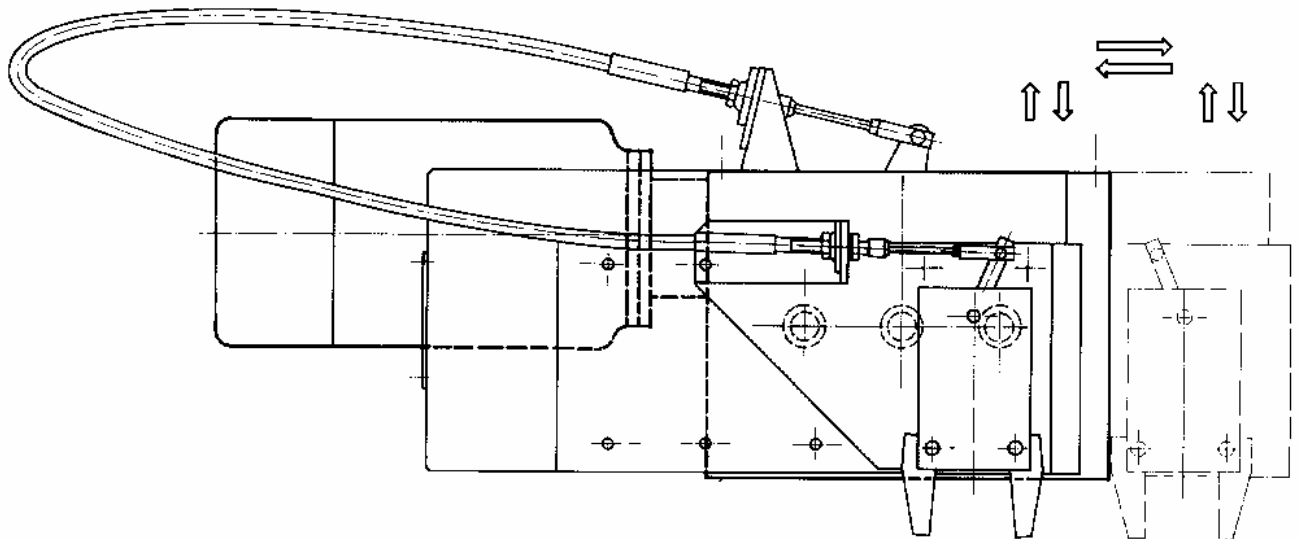

Fig. 29

13.4 Mechanical thrust grippers

Traversing, opening and closing of these press feeding grippers are obtained by a TANDEM CF3 drive. Traversing is obtained by a 2-station indexing drive and an adjustable stroke crank. Opening and closing is obtained by an oscillating drive and linkage transmission system. TANDEM CF3 is driven by the press's main shaft.

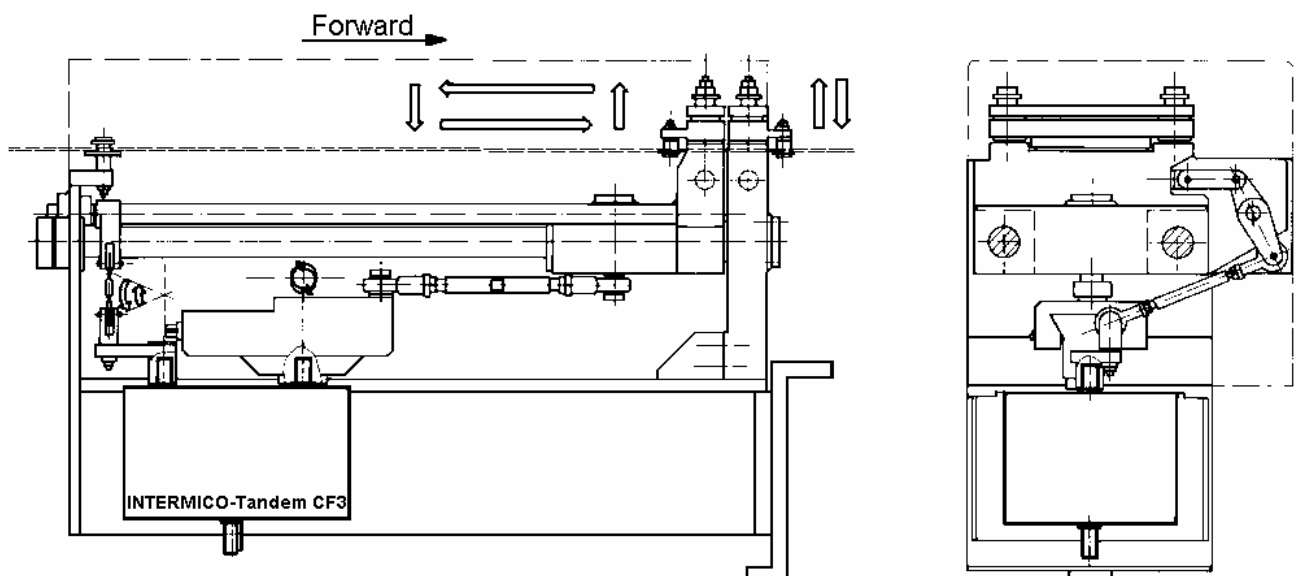

Fig. 30

13.5 Electromechanical lifting-carrying-placing equipment

Rotary motion is obtained by means of an IR series rotary table onto which the equipment holding the TANDEM CF3 mechanism, which supplies linear motion, is keyed.

The "IR" rotary table and "TANDEM CF3" mechanism are actuated separately by self-braking electric motors. The 2-3-4-station rotary table can turn the equipment by 180-120-90 degrees and reverse the direction of its movements by reversing the direction of rotation of its motor.

The TANDEM CF3 mechanism, instead, produces the linear movements. The horizontal (lengthwise) stroke is obtained by a 2-station indexing movement and a linear traversing drive. In both the end positions, this movement has dwell times during which the grippers are raised and lowered by an oscillating drive.

Opening and closing of the grippers may be controlled mechanically.

The output of electrical or pneumatic energy to be supplied to TANDEM CF3 and the equipment may be through the central hole of the rotary table.

This equipment assures perfect synchronism of all movements, high moving speeds and accurate positioning.

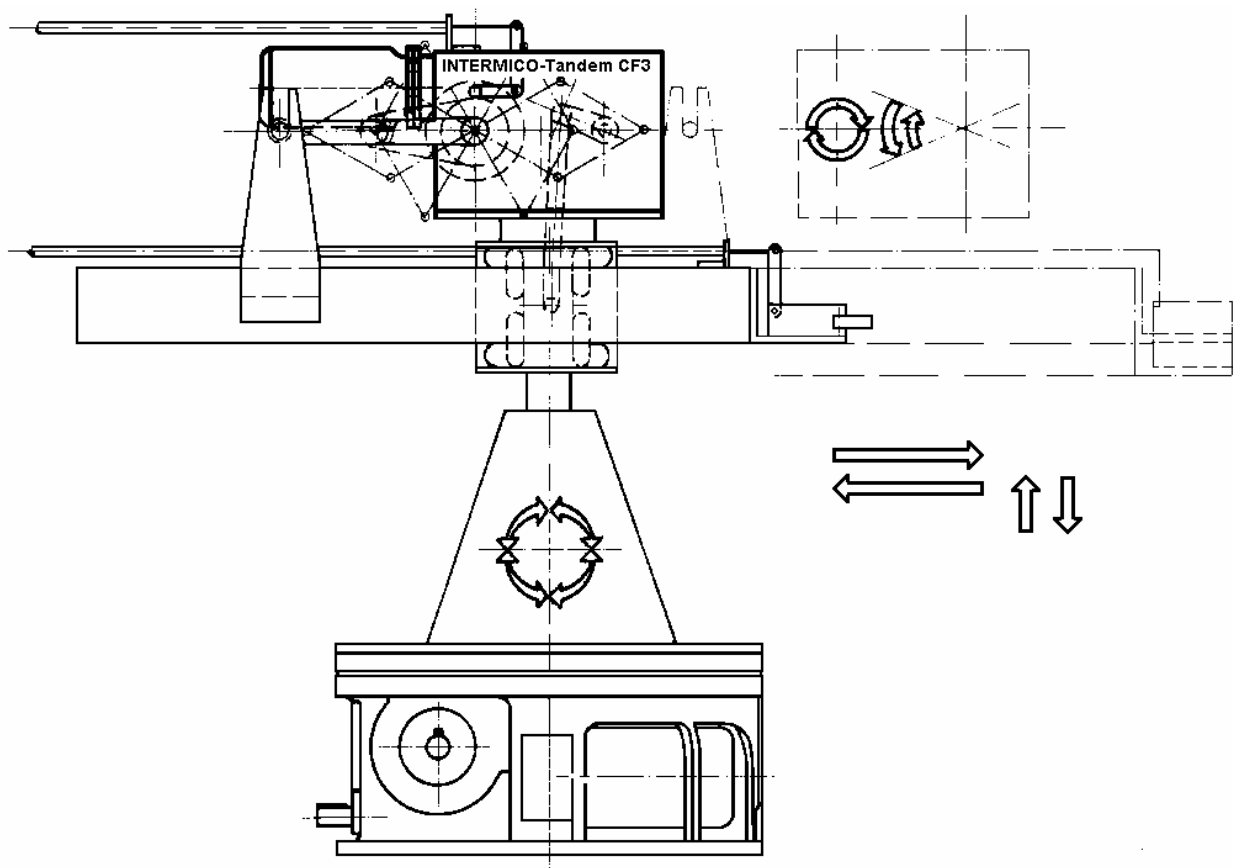

Fig. 31

13.6 Bar feed equipment

TANDEM CF3 controls the feed, opening and closing of bars. traversing is obtained by a 2-station indexing drive and an adjustable-stroke connecting rod-crank assembly.

Opening and closing of the bars is via an oscillating drive and a linkage system. TANDEM CF3 is powered directly by the main shaft of the press for perfect synchronism with the machine cycle.

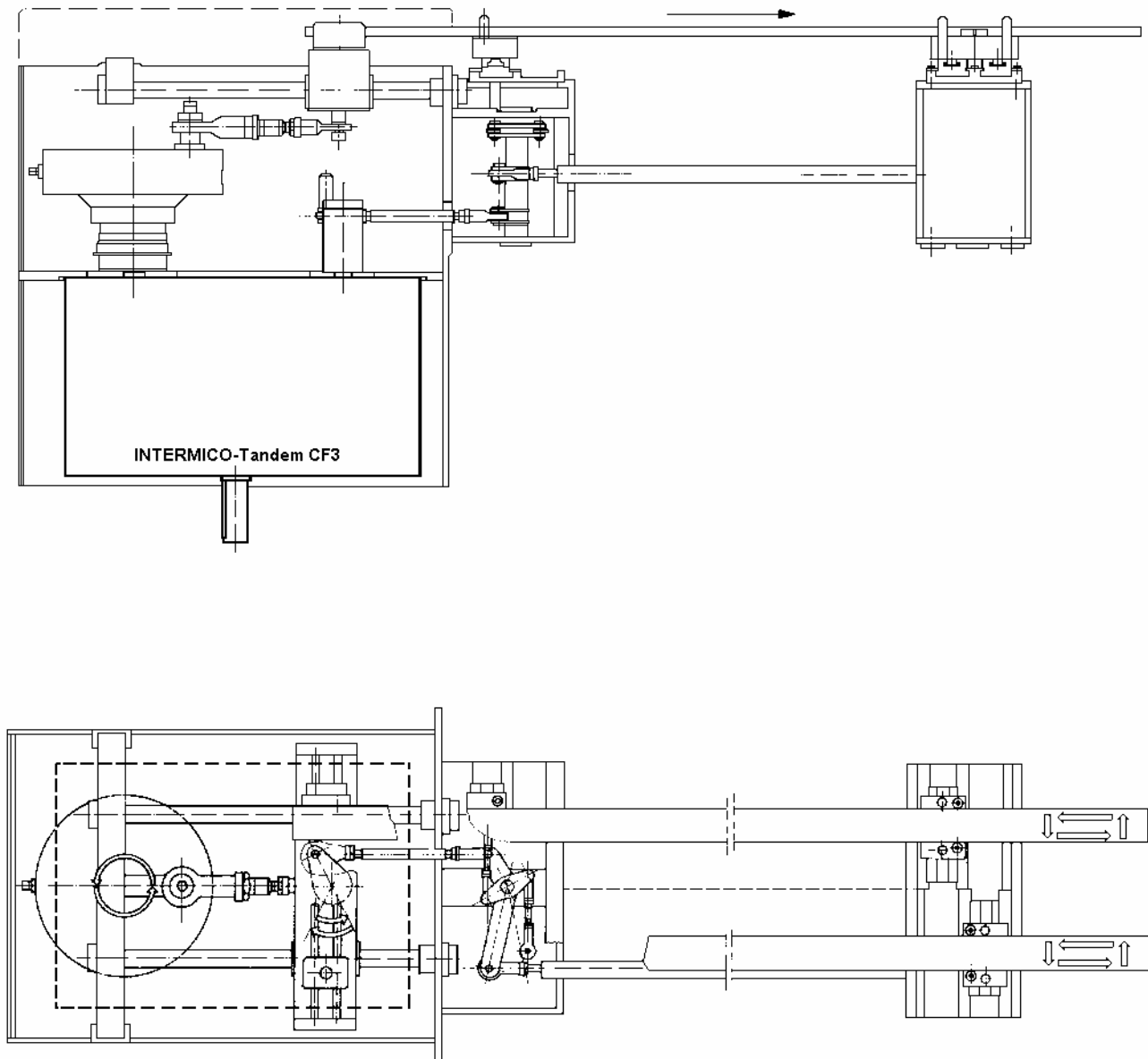

Fig. 32