

PARALLEL OSCILLATING DRIVES

165P•200P•250P•315P

CF3



- Prism- shaped sealed cast iron housing
- Outer surfaces machined, with support on 6 sides
- Possibility of mounting housing in all positions
- Parallel shafts in input and output
- Roller bearings on opposite taper roller shafts
- Oil-bath lubrication
- Worm gear reducer directly splined to housing
- Precise repeatable index motion
- Self locking in dwell and zero backlash
- Smooth and shock-free movement
- Bi-directional sense of motion



COLOMBO FILIPPETTI SPA

COLLABORATIVE ENGINEERING

CF1131 09-03

Via Rossini, 26 I-24040 CASIRATE D'ADDA -BG -Tel 0363-3251 Fax 0363-325252
<http://www.cofil.it> - E-mail cofil@cofil.it

Contents

PAG

1.	Introduction.....	2
2.	Description.....	2
3.	Timing diagram.....	2
4.	Specifications	3
5.	Assembly	7
6.	Versions.	7
7.	Drive components	8
8.	Standard housed units	9
9.	Optional housed units.....	10
10.	Input shaft	10
11.	Mounting positions	11
12.	Identification number.....	11

The units of measurement correspond with System International /Severity Index SI General tolerances of manufacture are conform to UNI – ISO 2768-1 UNI EN 22768-1

Illustrations and drawings according to UNI 3970 (ISO 128-82).

Method of projection of the drawings.

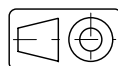

All rights reserved. No part of this catalogue may be duplicated.

COLOMBO FILIPPETTI may make any changes they feel necessary for the improvement of their products without advance notice.

COLOMBO FILIPPETTI may change any market components and accessories mentioned in this catalogue as they feel necessary.

This catalogue supersedes all earlier ones.



INTRODUCTION

The CF3 OSCILLATING DRIVES are parallel axis mechanisms which transform the constant rotary motion of the input shaft into intermittent oscillating motion of the output shaft by way of a conjugate cam transmission and roller feeler. The features which make the CF3 OSCILLATING DRIVES a high

quality, reliable product are their simple structure, principals of motion with mathematically calculated acceleration tested in numerous applications, the use of the most suitable design and production technology, precise, ongoing checks of the parts during the production cycle, and long

experience in the calculation, manufacture and application possibilities of cam mechanisms. The drives offer the precision, high speed, low vibration, silence, totally repeatable movement, versatility of application etc. required by the latest automatic machines.

DESCRIPTION

The width of oscillation of the output shaft is known as "ANGULAR STROKE", and is indicated by the letter "H".

The full cycle, comprising two revolutions of the same width in opposite directions (oscillation), with or without intermediate dwell periods, is produced by one complete revolution (360°) of the input shaft.

This cycle is divided into four periods or times which are named

according to the order of performance:

- 1: MOTION PERIOD
Indicated as "A"
- 2: DWELL PERIOD
Indicated as "B"
- 3: MOTION PERIOD
Indicated as "C"
- 4: DWELL PERIOD
Indicated as "D"

The point at which this chronological sequence begins is the "CYCLE STARTING POINT";

this point is always followed by MOTION PERIOD "A", regardless of the direction of rotation of the input shaft and of the direction of rotation to be obtained from the output shaft during MOTION PERIOD "A".

The PHASE AXIS, which coincides with the axis of the input shaft keyway, is always located halfway along indexing period "A".

TIMING DIAGRAM

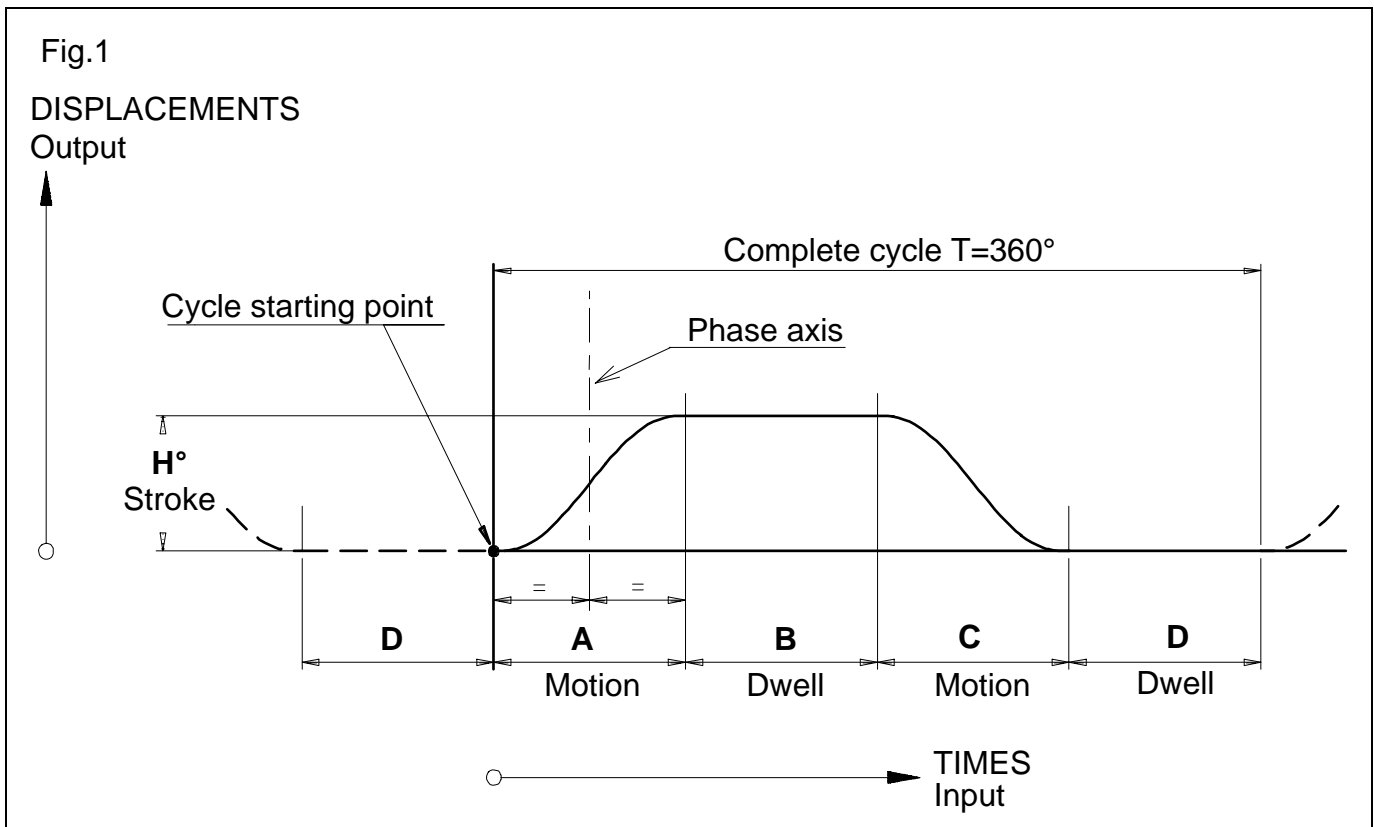

SPECIFICATIONS

OSCILLATING DRIVE CODE						Static torque Ms [daN m]	Dynamic output torques Mu [daN m]						Accele- ration factor Ca	Input torque factor K
Angular stroke H°[deg]	Dimens. series	PERIODS T° [deg] OF CYCLE					R.P.M.							
		A motion	B dwell	C motion	D dwell		25	50	75	100	150	200		
15	165 P	30	150	30	150	287	152	151	151	141	124	112	5.53	0.49
	200 P					400	222	220	219	214	188	170		
	250 P					773	406	402	397	366	321	291		
	315 P					1201	715	702	630	576	506	428		
	165 P	30	300	30	0	287	151	151	150	143	126	114	5.31	0.47
	200 P					400	220	219	217	215	190	172		
	250 P					773	404	401	396	370	324	234		
	315 P					1201	713	700	637	582	511	437		
	165 P	45	135	45	135	287	148	146	129	118	103	94	5.53	0.33
	200 P					400	224	223	199	182	160	145		
	250 P					773	397	377	333	304	267	242		
	315 P					1201	701	595	525	480	422	382		
	165 P	45	270	45	0	287	148	145	128	117	103	93	5.31	0.32
	200 P					400	223	222	198	181	159	144		
	250 P					773	405	389	343	314	275	249		
	315 P					1201	700	593	524	479	420	381		
	165 P	60	120	60	120	287	149	134	118	108	95	86	5.53	0.25
	200 P					400	236	203	180	164	144	130		
	250 P					773	406	354	312	286	251	227		
	315 P					1201	656	532	470	430	377	341		
	165 P	60	240	60	0	287	148	133	117	107	94	85	5.31	0.24
	200 P					400	243	203	179	164	144	130		
	250 P					773	405	351	310	284	249	225		
	315 P					1201	652	529	467	427	375	339		
	165 P	90	90	90	90	287	147	119	105	96	85	77	5.53	0.16
	200 P					400	218	177	156	143	126	114		
	250 P					773	384	312	275	252	221	200		
	315 P					1201	563	457	404	369	324	293		
	165 P	90	180	90	0	287	145	118	104	95	83	76	5.31	0.16
	200 P					400	215	174	154	141	124	112		
	250 P					773	379	307	271	248	218	197		
	315 P					1201	557	452	399	365	320	290		
165 P	120	60	120	60	287	135	110	97	88	78	70	5.53	0.12	
200 P					400	198	161	142	130	114	103			
250 P					773	354	287	254	232	203	184			
315 P					1201	509	413	365	334	293	265			
165 P	120	120	120	0	287	134	109	96	88	77	70	5.31	0.12	
200 P					400	195	158	139	127	112	101			
250 P					773	350	284	251	229	201	182			
315 P					1201	504	408	361	330	289	262			
165 P	150	30	150	30	287	127	103	91	83	73	66	5.53	0.10	
200 P					400	184	149	132	120	106	96			
250 P					773	333	270	239	218	191	173			
315 P					1201	473	383	339	310	272	246			
165 P	150	60	150	0	287	125	102	90	82	72	65	5.31	0.09	
200 P					400	180	146	129	118	103	94			
250 P					773	326	265	234	214	188	170			
315 P					1201	466	378	334	305	268	243			
165 P	180	0	180	0	287	121	98	86	79	69	63	5.53	0.08	
200 P					400	173	140	124	113	100	90			
250 P					773	314	255	225	206	181	164			
315 P					1201	445	361	319	291	256	232			

SPECIFICATIONS

Angular stroke H°[deg]	OSCILLATING DRIVE CODE				Static torque Ms [daN m]	Dynamic output torques Mu [daN m]						Accele- ration factor Ca	Input torque factor K	
	Dimens. series	PERIODS T°[deg] OF CYCLE				RPM								
		A motion	B dwell	C motion		D dwell	25	50	75	100	150			200
20	165 P	45	135	45	135	283	163	162	162	161	146	132	5.53	0.44
	200 P					395	252	251	250	240	210	190		
	250 P					764	435	433	429	425	377	342		
	315 P					1183	649	641	627	608	542	478		
	165 P	45	270	45	0	283	162	161	161	160	145	131	5.31	0.42
	200 P					395	254	253	252	238	209	189		
	250 P					764	432	430	427	422	375	339		
	315 P					1183	648	640	627	608	538	483		
	165 P	60	120	60	120	283	171	171	164	150	131	119	5.53	0.33
	200 P					395	248	247	232	212	186	168		
	250 P					764	458	457	423	387	339	307		
	315 P					1183	638	634	603	552	484	438		
	165 P	60	240	60	0	283	170	170	162	148	130	118	5.31	0.32
	200 P					395	244	243	230	210	184	167		
	250 P					764	483	477	421	385	338	306		
	315 P					1183	637	633	598	547	480	435		
	165 P	75	105	75	105	283	177	171	151	138	121	110	5.53	0.26
	200 P					395	245	241	213	195	171	155		
	250 P					764	497	444	392	359	315	285		
	315 P					1183	633	624	551	504	442	400		
	165 P	75	210	75	0	283	178	169	149	136	120	108	5.31	0.25
	200 P					395	236	235	209	192	168	152		
	250 P					764	478	438	387	354	310	281		
	315 P					1183	632	616	544	497	436	395		
	165 P	90	90	90	90	283	184	160	142	130	114	103	5.53	0.22
	200 P					395	244	225	198	181	159	144		
	250 P					764	494	415	367	335	294	266		
	315 P					1183	630	584	516	472	414	375		
	165 P	90	180	90	0	283	174	158	139	127	112	101	5.31	0.21
	200 P					395	231	220	195	178	156	142		
	250 P					764	468	408	361	330	289	262		
	315 P					1183	629	576	509	466	409	370		
165 P	120	60	120	60	283	179	145	128	117	103	93	5.53	0.16	
200 P					395	242	202	179	163	143	130			
250 P					764	462	375	331	303	266	241			
315 P					1183	627	526	465	425	373	338			
165 P	120	120	120	0	283	171	143	126	115	101	91	5.31	0.16	
200 P					395	226	199	175	160	141	127			
250 P					764	454	368	325	298	261	236			
315 P					1183	626	519	459	420	368	333			
165 P	150	30	150	30	283	166	135	119	109	95	86	5.53	0.13	
200 P					395	231	187	165	151	133	120			
250 P					764	429	348	307	281	246	223			
315 P					1183	603	489	432	395	347	314			
165 P	150	60	150	0	283	162	132	116	106	93	85	5.31	0.13	
200 P					395	222	183	162	148	130	118			
250 P					764	420	340	301	275	241	218			
315 P					1183	594	482	426	389	341	309			
165 P	180	0	180	0	283	156	127	112	102	90	81	5.53	0.11	
200 P					395	217	176	155	142	125	113			
250 P					764	403	327	289	264	232	210			
315 P					1183	572	464	410	375	329	289			

SPECIFICATIONS

OSCILLATING DRIVE CODE						Static torque Ms [daN m]	Dynamic output torques Mu [daN m]						Accele- ration factor Ca	Input torque factor K
Angular stroke H°[deg]	Dimens. series	PERIODS T°[deg] OF CYCLE					RPM							
		A motion	B dwell	C motion	D dwell		25	50	75	100	150	200		
30	165 P	45	135	45	135	275	190	190	189	188	184	167	5.53	0.66
	200 P					386	257	256	254	252	245	234		
	250 P					742	521	518	513	506	477	432		
	315 P					1138	689	676	656	628	547	433		
	165 P	45	270	45	0	275	196	196	195	194	172	155	5.31	0.63
	200 P					386	260	259	257	255	240	217		
	250 P					742	525	523	518	505	443	401		
	315 P					1138	681	670	650	623	545	436		
	165 P	60	120	60	120	275	190	190	176	161	141	128	5.53	0.49
	200 P					386	251	251	246	225	197	179		
	250 P					742	509	508	455	416	365	330		
	315 P					1138	724	717	706	654	574	519		
	165 P	60	240	60	0	275	187	186	173	158	139	126	5.31	0.47
	200 P					386	247	246	242	221	194	176		
	250 P					742	500	498	448	410	359	325		
	315 P					1138	768	761	712	651	571	517		
	165 P	75	105	75	105	275	188	182	160	147	129	117	5.53	0.39
	200 P					386	248	248	224	205	179	163		
	250 P					742	503	469	415	379	333	301		
	315 P					1138	792	749	662	605	531	481		
	165 P	75	210	75	0	275	180	178	157	144	126	114	5.31	0.38
	200 P					386	238	237	219	200	176	159		
	250 P					742	482	460	406	371	326	295		
	315 P					1138	785	735	649	594	521	472		
	165 P	90	90	90	90	275	186	168	149	136	119	108	5.53	0.33
	200 P					386	246	234	207	189	166	150		
	250 P					742	499	435	384	351	308	279		
	315 P					1138	849	699	618	565	496	449		
	165 P	90	180	90	0	275	176	165	146	133	117	106	5.31	0.32
	200 P					386	232	229	203	185	162	147		
	250 P					742	471	426	376	344	302	273		
	315 P					1138	807	685	605	554	486	440		
	165 P	120	60	120	60	275	185	150	133	122	107	97	5.53	0.25
	200 P					386	244	209	185	169	148	134		
	250 P					742	479	389	343	314	276	250		
	315 P					1138	776	630	556	509	446	404		
	165 P	120	120	120	0	275	171	147	130	119	105	95	5.31	0.24
	200 P					386	227	205	181	166	145	132		
	250 P					742	460	381	337	308	270	245		
	315 P					1138	761	618	546	499	438	396		
	165 P	150	30	150	30	275	171	139	123	112	98	89	5.53	0.20
	200 P					386	238	193	170	156	137	124		
	250 P					742	442	358	317	289	254	230		
	315 P					1138	717	582	514	470	412	374		
	165 P	150	60	150	0	275	167	136	120	110	96	87	5.31	0.19
	200 P					386	222	189	167	153	134	121		
	250 P					742	432	350	310	283	248	225		
	315 P					1138	702	569	503	460	404	365		
165 P	180	0	180	0	275	160	130	115	105	92	83	5.53	0.16	
200 P					386	223	181	160	146	128	116			
250 P					742	414	336	297	271	238	215			
315 P					1138	673	546	482	441	387	351			

SPECIFICATIONS

Angular stroke H°[deg]	OSCILLATING DRIVE CODE					Static torque Ms [daN m]	Dynamic output torques Mu [daN m]						Accele- ration factor Ca	Input torque factor K
	Dimension. series	PERIODS T°[deg] OF CYCLE					RPM							
		A motion	B dwell	C motion	D dwell		25	50	75	100	150	200		
45	165 P	60	120	60	120	255	194	194	194	193	191	184	5.53	0.74
	200 P					361	257	256	255	253	247	239		
	250 P					689	521	518	514	508	491	468		
	315 P					1137	888	877	860	836	767	671		
	165 P	60	240	60	0	255	190	189	188	187	183	169	5.31	0.71
	200 P					361	251	250	248	245	238	227		
	250 P					689	509	506	501	493	473	437		
	315 P					1137	868	857	838	851	775	692		
	165 P	75	105	75	105	255	191	191	191	183	161	146	5.53	0.59
	200 P					361	253	252	251	250	225	204		
	250 P					689	512	511	508	474	416	377		
	315 P					1137	875	868	831	760	667	604		
	165 P	75	210	75	0	255	182	182	181	172	151	137	5.31	0.57
	200 P					361	241	240	239	237	211	191		
	250 P					689	489	487	483	445	390	354		
	315 P					1137	835	828	782	715	627	568		
	165 P	90	90	90	90	255	189	189	175	160	141	127	5.53	0.49
	200 P					361	250	250	245	224	196	178		
	250 P					689	507	506	453	415	364	329		
	315 P					1137	866	826	730	667	585	530		
	165 P	90	180	90	0	255	178	177	171	157	137	124	5.31	0.47
	200 P					361	235	234	233	219	192	174		
	250 P					689	476	475	443	405	355	322		
	315 P					1137	815	808	713	652	572	518		
	165 P	120	60	120	60	255	186	176	156	142	125	113	5.53	0.37
	200 P					361	247	246	218	200	175	159		
	250 P					689	500	455	402	368	322	292		
	315 P					1137	856	736	650	595	522	473		
	165 P	120	120	120	0	255	173	172	152	139	122	111	5.31	0.36
	200 P					361	228	228	214	196	172	155		
	250 P					689	463	445	394	360	316	286		
	315 P					1137	793	720	636	582	511	462		
165 P	150	30	150	30	255	185	162	143	131	115	104	5.53	0.30	
200 P					361	244	229	203	185	162	147			
250 P					689	496	419	370	338	297	269			
315 P					1137	834	677	598	546	479	434			
165 P	150	60	150	0	255	169	158	140	128	112	102	5.31	0.28	
200 P					361	224	223	198	181	159	144			
250 P					689	454	410	362	331	291	263			
315 P					1137	777	661	584	534	468	424			
165 P	160	0	180	0	255	184	152	134	123	108	97	5.53	0.25	
200 P					361	243	217	192	175	154	139			
250 P					689	484	393	347	317	278	252			
315 P					1137	779	632	558	511	448	406			

OTHER SPECIAL MOVEMENT WILL BE SUPPLIED ON REQUEST

ASSEMBLY

The CF3 OSCILLATING DRIVES can be assembled in four different ways, regardless of the mounting position. The type of assembly depends on the direction of rotation of the motion input and output shafts. If the CF3 OSCILLATING DRIVE is viewed from the output shaft side, "Side B", it can be seen that:

1 The input shaft can rotate

clockwise, in which case it is marked "D" or anticlockwise, in which case it is marked "S".

2 If motion period "A" only is considered, the output shaft can rotate clockwise, and is marked "D", or anti-clockwise, and is marked "S". Motion period "C" always rotates in the opposite output direction to period "A".

Four assembly possibilities of the CF3 OSCILLATING DRIVE result from the combination of directions of rotation of the two motion input and output shafts, the same being shown in the figures below.

Unless otherwise specified, the CF3 OSCILLATING DRIVE will be supplied with assembly "DS".

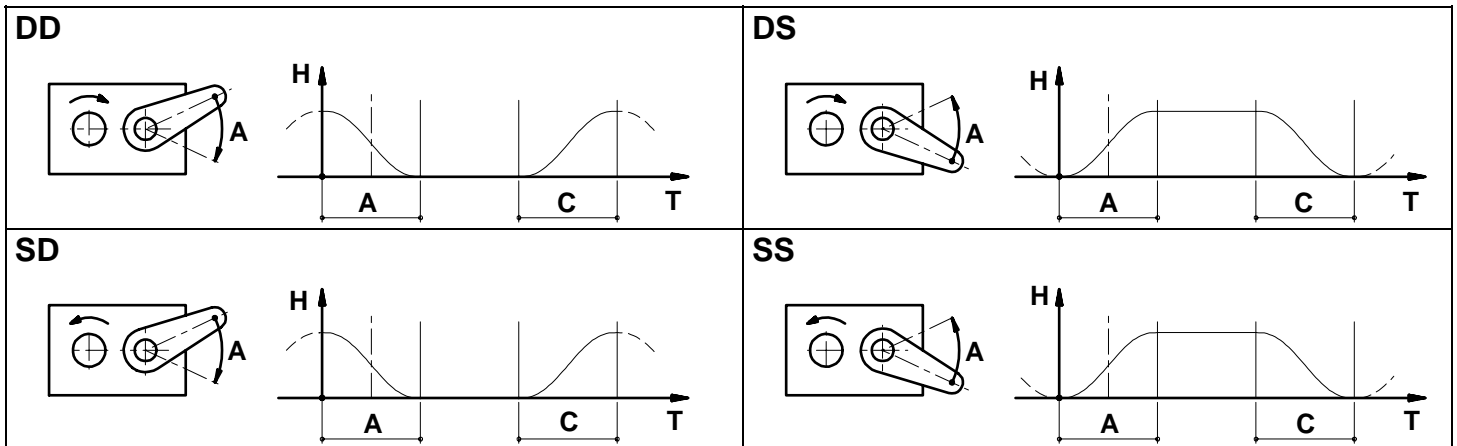

VERSIONS

The CF3 OSCILLATING DRIVES are normally supplied in the following versions.

For further information regarding motor drive systems, please contact our technical staff.

<p>VGS drive components</p>	<p>VS standards units</p>	<p>VL units with optional input</p> <p>optional output VO optional input and output VOL</p>
<p>VR standard + reducer</p> <p>optional output + reducer VOR</p>	<p>VRP standard + reducer with flange</p> <p>optional output+ reducer with flange VORP</p>	<p>VRM standard + motor and reducer VRA with brake motor</p> <p>optional output+ motor and reducer VORM with brake motor VORA</p>

DRIVE COMPONENTS

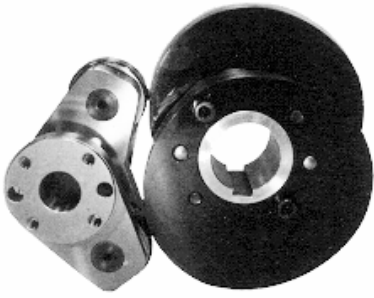

- Parallel shaft
- Separate and pre-coupled cam/follower units
- Cam hub with hollow shaft and keyway
- High-strength alloy steel cams with hardened, ground contours
- Follower hub with central through hole and flange mount on both sides.
- High load capacity with special yoke-mounted cam followers

Fig.2

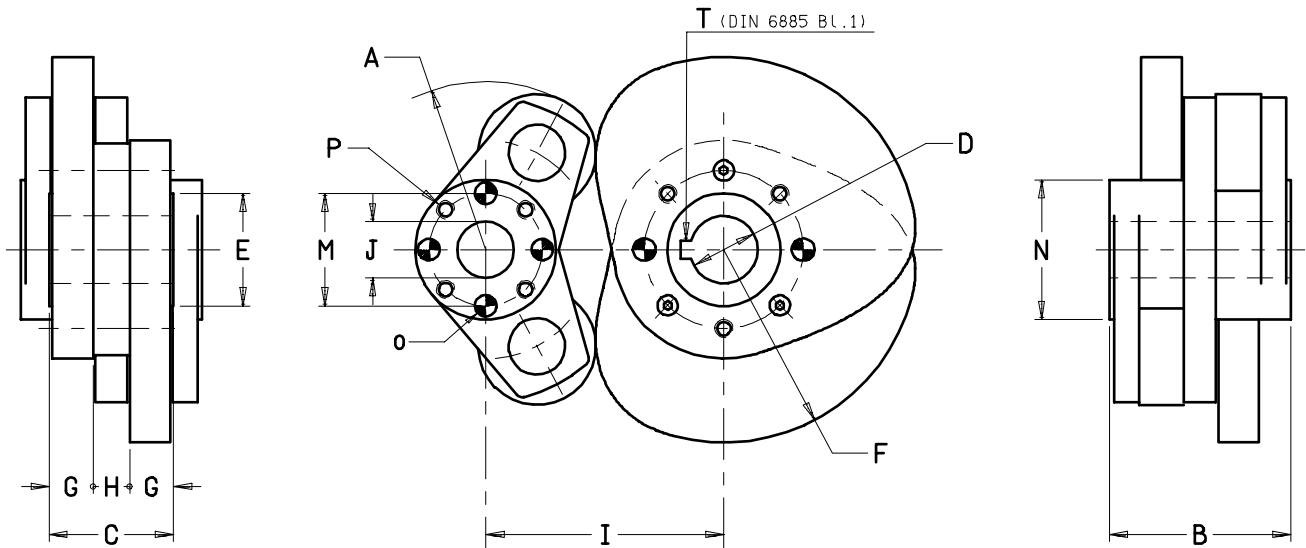

Series	A	B	C	D _{H7}	E _{h6}	F _{max.}	G	H	I	J _{H7}	M	N	O	P	T
165 P	116	115	85	45	85	132	27	24	165	40	80	104	9.5x16	M8x16	14x9
200 P	142	130	95	55	110	161	30	28	200	50	100	127	11.5x17	M10x17	16x10
250 P	175.5	150	110	85	140	201	35	31	250	65	125	160	13.5x30	M12x30	22x14
315 P	215	250	150	100	170	251	45	56	315	80	160	200	15.5x35	M14x35	28x16

Notes

- Reversal of the direction of rotation of the input shaft also reverses the chronological sequence of the cycle periods. This is equivalent to crossing the Timing diagram from right to left.
- Keyway "T" of the cam hub is positioned halfway along indexing period "A".

- The four holes for dowel "O" and the four threaded holes "P" are drilled on both sides of the output shaft. The dimensions of hole "O" shown in the table are such as to allow simultaneous boring with the part to be splined at the mounting stage. These holes are located in the positions shown in the figure when the

oscillating drive in halfway along angular stroke "H".

- Correct operation of the OSCILLATING DRIVE is guaranteed by three essential conditions:
 - Parallel shafts.
 - Possibility of pre-loading the followers in the cam dwell periods.
 - Suitable lubrication of mechanism.

STANDARD HOUSED UNITS

- Prism- shaped sealed cast iron housing
- Outer surfaces machined, with support on 6 sides
- Possibility of mounting housing in all positions
- Parallel shafts in input and output
- Roller bearings on opposite taper roller shafts
- Oil-bath lubrication
- Worm gear reducer directly splined to housing

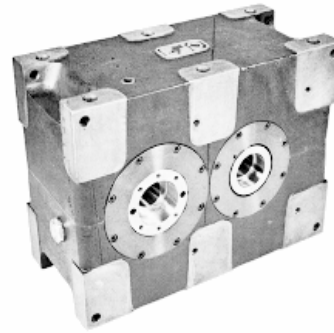

Notes

- Reversal of the direction of rotation of the input shaft also reverses the chronological. This is equivalent to crossing the Timing/Indexing diagram from right to left.
- Hollow input shaft keyway "T" is in the position shown when the OSCILLATING DRIVE is halfway along motion period "A".
- The four holes for dowel "O" and the four threaded holes "P" are drilled on both sides of the output shaft. The dimensions of holes "O" shown in the table are such as to allow simultaneous boring with the part to be splined. These holes are located in the position shown in the figure when the oscillating drive is halfway along the angular stroke.
- The machined surfaces of the housing can be drilled to a maximum depth of 30 mm to obviate the need for tie-bars connecting the two halves of the housing.
- Through holes "Z" are of standard manufacture; for frontal fixing of the housing they can be tapped.

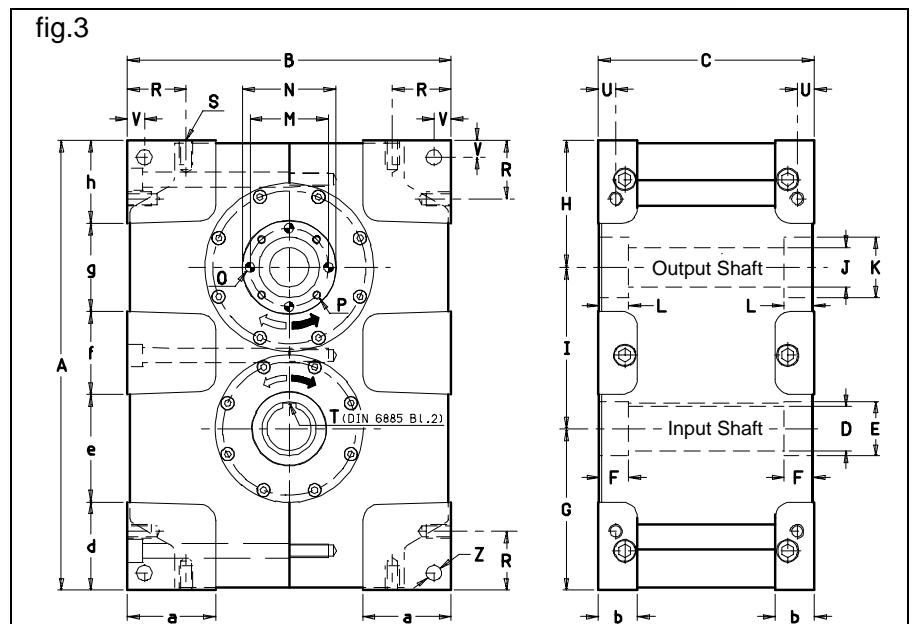

- Fixing holes "S" are only drilled on the side shown as the mounting side.
- The oil Fill / Level / Drain holes are drilled on the side shown in the paragraph MOUNTING POSITIONS
- Correct operation of the CF3 OSCILLATING DRIVE is obtained by connecting the input and output shafts of the OSCILLATING DRIVE rigidly to the machine. For this reason, flexible

- transmission parts or parts which could introduce backlash into kinematic chain should not be used.
- Overload clutches are effective in protecting the CF3 OSCILLATING DRIVE only if fitted to the output shaft of the drive.
- The housed CF3 OSCILLATING DRIVES are supplied **without lubricating oil**. The recommended oil is AGIP "BLASIA 150".

Series	A	B	C	D H7	E H8	F	G	H	I	J H7	K H7	L	M	N	O
165 P	460	330	220	45	55	30	165	130	165	40	62	30	80	95	9.5x20
200 P	550	400	250	55	65	30	200	150	200	50	80	35	100	120	11.5x25
250 P	700	500	300	85	100	30	250	200	250	65	95	50	125	150	13.5x30
315 P	880	630	400	100	130	30	315	250	315	80	120	62	160	190	15.5x35

Series	P	R	S	T	U	V	Z	a	b	d	e	f	g	h	Weight
165 P	M8x20	60	M14x25	14x9	17.5	17.5	15.5	90	40	90	110	85	90	85	136
200 P	M10x25	75	M16x30	16x10	20	20	17.5	115	50	110	130	100	120	90	235
250 P	M12x30	90	M18x35	22x14	25	25	19.5	145	50	145	160	115	160	120	408
315 P	M14x35	120	M20x40	28x16	30	30	21	180	55	215	180	155	160	170	775

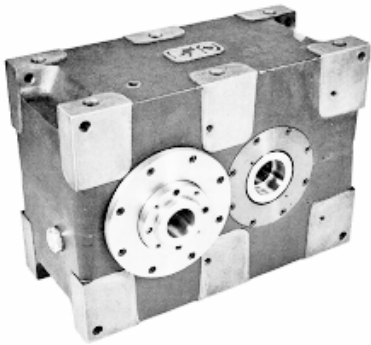

HOUSED UNITS WITH OPTIONAL OUTPUT

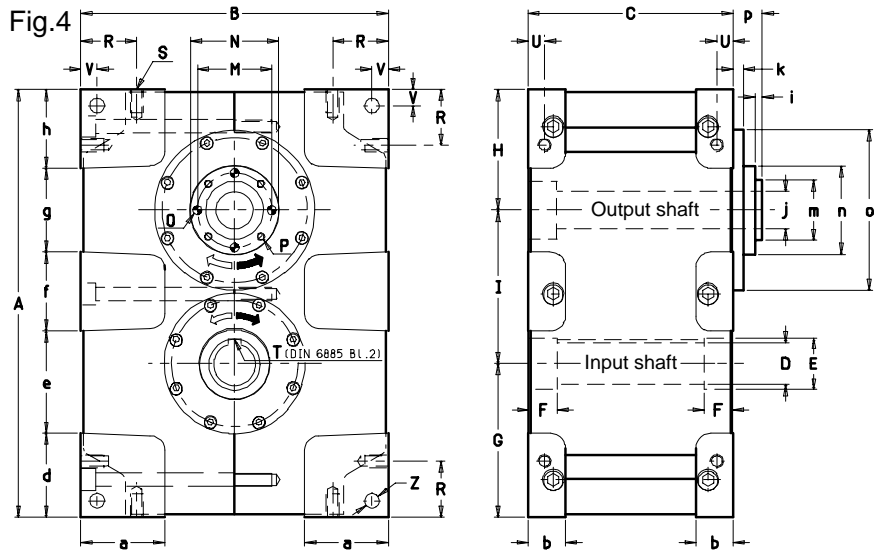

Notes

In this version, the CF3 OSCILLATING DRIVE retains all the construction features of the standard version, with the following exceptions:

- the external diameter of the output flange projects from the side of the housing
- the output shaft with central through hole is fitted with a flange coupling protruding from one side only.

Series	A	B	C	D H7	E H8	F	G	H	I	M	N	O	P	R	S	T	U
165 P	460	330	220	45	55	30	165	130	165	80	95	9.5x20	M8x20	60	M14x25	14x9	17.5
200 P	550	400	250	55	65	30	200	150	200	100	120	11.5x25	M10x25	75	M16x30	16x10	20
250 P	700	500	300	85	100	30	250	200	250	125	150	13.5x30	M12x30	90	M18x35	22x14	25
315 P	880	630	400	100	130	30	315	250	315	160	190	15.5x35	M14x35	120	M20x40	28x16	30

Series	V	Z	a	b	d	e	f	g	h	i	j H7	k	m h7	n h7	o g7	p	Weight
165 P	17.5	15.5	90	40	90	110	85	90	85	8	40	11	65	95	173	31	140
200 P	20	17.5	115	50	110	130	100	120	90	10	50	14	80	120	210	40	241
250 P	25	19.5	145	50	145	160	115	160	120	10	65	18	100	150	260	46	425
315 P	30	21	180	55	215	180	155	160	170	10	80	25	125	190	295	62	796

OPTIONAL INPUT SHAFTS

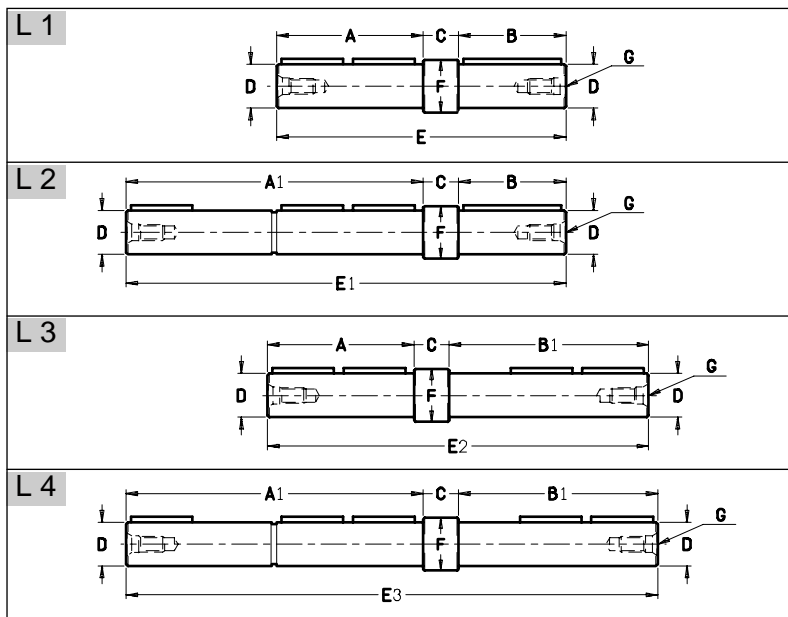

This series of OSCILLATING DRIVES is manufactured with hollow input shaft. Projecting input shafts with the dimensions shown in the table and centres as per DIN 332 Bl.2 will be supplied on request.

Series	165P	200P	250P	315P
A	150	180	230	330
A1	304	334	444	584
B	110	110	170	210
B1	204	224	274	314
C	36	36	36	36
D	45	55	85	100
D1	50	60	85	100
E	296	326	436	576
E1	450	480	650	830
E2	390	440	540	680
E3	544	594	754	934
F	54	64	99	129
G	M16x36	M20x42	M20x42	M24x50



MOUNTING POSITIONS

- The characteristic shape of the housing allows it to be mounted in all positions.
- On placing the order, please specify:
 - on which side of the housing the mounting holes should be drilled
 - on which side (A or B) the output shaft should project in the optional version.
- If the mounting position is not

specified, the OSCILLATING DRIVE will be supplied for mounting in position MA, with mounting holes on side F and optional output on side A.

Series	165P	200P	250P	315P
a	125	150	170	240
b	75	90	100	130
c	100	130	160	230
d	53	63	63	68
e	170	210	260	330

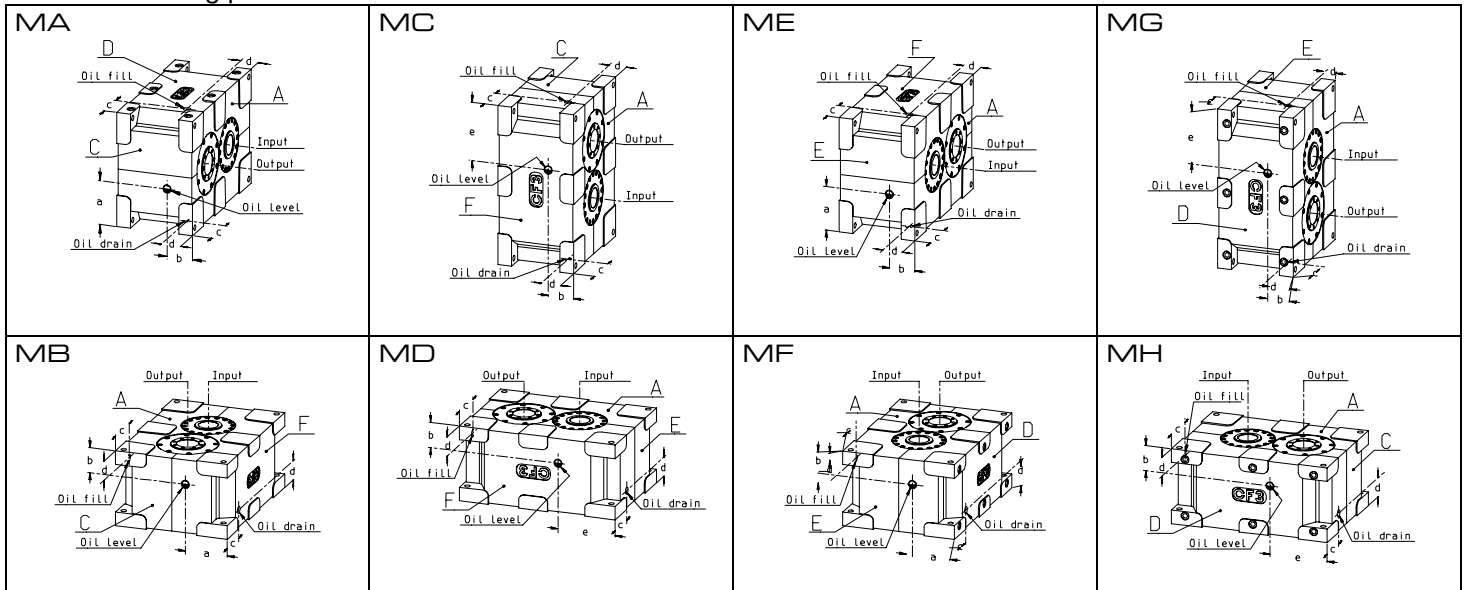
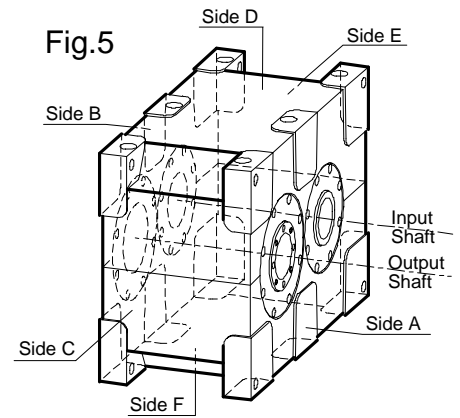

For mechanisms running at less than 30 indexes/minute which are required to be mounted in any of the positions MB, MD, MF or MH, it may be necessary to fit an external tube to effectively lift the level of the oil in order to lubricate the top bearings. In this event a breather plug would be fitted to the top side of the unit. Up to size 250P it is generally possible to lubricate the top bearings with grease.

IDENTIFICATION NUMBER

The identification number of the OSCILLATING DRIVES is made up in accordance with the chart. For version VR, V..P, V..M and V..A when placing the order it is essential to specify all details required to identify the characteristics of the motor and reducer requested with no risk of confusion (reduction ratios, hp, no. of revs, voltage, frequency etc.)

Example of identification number CF3 OSCILLATING DRIVE	H15	165P	30/150/30/150	DS	VOL	MA	F	B	L1
angular stroke _____									
dimensional series _____									
cycle periods _____									
assembly _____									
version _____									
mounting position _____									
side with mounting holes _____									
side with output shaft _____									
input shaft _____									