

PARALLEL INDEXING DRIVES

65P•80P•105P•130P

CF3



- Prism-shaped sealed cast iron housing
- Outer surfaces machined, whit support on 6 sides.
- Possibility of mounting housing in all positions.
- Parallel shafts projecting in input and output.
- Roller bearings on opposite taper roller shafts.
- Oil-bath lubrication.
- Worm gear reducer splined directly to housing.
- Precise repeatable index motion.
- Self locking in dwell and zero backlash.
- Smooth and shock-free movement
- Bidirectional sense of motion.



COLOMBO FILIPPETTI SPA
COLLABORATIVE ENGINEERING

CF1101 09-03

Via Rossini, 26 I-24040 CASIRATE D'ADDA -BG -Tel 0363-3251 Fax 0363-325252
<http://www.cofil.it> - E-mail cofil@cofil.it

Contents

PAG

1.	Specifications	2
2.	Versions	4
3.	Drive components.	5
4.	Housed units	6
5.	Mounting positions	7
6.	Identification number.....	7
7.	Reducer mounting possibilities.....	8

The units of measurement correspond with System International /Severity Index SI General tolerances of manufacture are conform to UNI – ISO 2768-1 UNI EN 22768-1

Illustrations and drawings according to UNI 3970 (ISO 128-82).
Method of projection of the drawings.

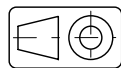

All rights reserved. No part of this catalogue may be duplicated.

COLOMBO FILIPPETTI may make any changes they feel necessary for the improvement of their products without advance notice.

COLOMBO FILIPPETTI may change any market components and accessories mentioned in this catalogue as they feel necessary.

This catalogue supersedes all earlier ones.



SPECIFICATIONS

Index drive code	Number of stops S	Index period B° [deg]	Static Torque Ms [daN m]	Dynamic output torque Mu [daN m]						Velocity factor Cv	Acceleration factor Ca	Input torque factor K	
				Indexes / min.									
				50	100	200	300	400	500				
65P-1-300	1	300	7.5	6.1	5.0	3.9	3.4	2.9	2.6	1.27	8.01	0.86	
80P-1-300			14.5	12.6	10.2	8.1	6.9	6.0	5.3				
105P-1-300			30.0	25.8	20.8	16.5	14.1	12.4	10.9				
130P-1-300			57.0	46.9	37.9	30.1	25.7	22.5	19.8				
65P-1-330		330	7.5	5.3	4.3	3.4	2.9	2.6	2.3	1.35	7.02	0.83	
80P-1-330			14.5	10.9	8.8	7.0	6.0	5.2	4.6				
105P-1-330			30.0	22.4	18.1	14.4	12.3	10.7	9.5				
130P-1-330			57.0	40.5	32.7	26.0	22.2	19.4	17.1				
65P-2-150	2	150	6.0	4.8	4.7	4.6	4.3	4.0	3.6	1.27	8.01	0.86	
80P-2-150			13.0	10.2	10.1	9.7	9.1	8.3	7.3				
105P-2-150			27.0	22.7	22.4	21.4	19.7	17.4	14.6				
130P-2-150			52.0	43.2	42.4	39.7	35.1	28.9	21.2				
65P-2-180		180	6.0	4.8	4.8	4.5	3.9	3.4	3.0	1.40	6.62	0.79	
80P-2-180			13.0	10.4	10.3	9.2	7.9	6.9	6.1				
105P-2-180			27.0	23.1	22.9	19.0	16.2	14.2	12.5				
130P-2-180			52.0	43.9	43.2	34.4	29.4	25.7	22.7				
65P-2-210		210	6.0	4.9	4.8	4.2	3.6	3.2	2.8	1.40	6.62	0.68	
80P-2-210			13.0	10.4	10.4	8.6	7.4	6.5	5.7				
105P-2-210			27.0	23.2	22.5	17.9	15.3	13.3	11.8				
130P-2-210			52.0	44.2	40.8	32.4	27.7	24.2	21.4				
65P-2-240		240	6.0	4.9	4.9	4.0	3.5	3.0	2.7	1.40	6.62	0.59	
80P-2-240			13.0	10.5	10.3	8.2	7.0	6.1	5.4				
105P-2-240			27.0	23.5	21.4	17.0	14.5	12.7	11.2				
130P-2-240			52.0	44.6	38.8	30.8	26.4	23.0	20.3				
65P-2-270		270	6.0	5.5	4.8	3.8	3.3	2.8	2.5	2.00	6.28	0.87	
80P-2-270			13.0	11.8	9.9	7.9	6.7	5.9	5.2				
105P-2-270			27.0	25.2	20.4	16.2	13.8	12.1	10.7				
130P-2-270			52.0	45.4	36.6	29.1	24.9	21.8	19.2				
65P-3-120		3	120	7.5	5.6	5.5	5.3	5.1	4.7	4.3	1.40	6.62	0.79
80P-3-120				14.5	12.0	11.9	11.5	10.8	10.0	8.9			
105P-3-120				30.0	26.6	26.3	25.3	23.6	20.8	18.4			
130P-3-120				57.0	50.3	49.7	47.1	42.8	37.1	30.1			
65P-3-150	150		7.5	5.5	5.5	5.3	4.9	4.3	3.8	1.40	6.62	0.63	
80P-3-150			14.5	11.9	11.8	11.4	10.0	8.8	7.8				
105P-3-150			30.0	26.3	26.1	24.3	20.8	18.2	16.0				
130P-3-150			57.0	49.9	49.4	44.3	37.9	33.1	29.2				
65P-3-180	180		7.5	6.2	5.7	4.6	3.9	3.4	3.0	1.76	5.53	0.66	
80P-3-180			14.5	13.3	11.8	9.4	8.0	7.0	6.2				
105P-3-180			30.0	29.4	24.4	19.4	16.5	14.5	12.8				
130P-3-180			57.0	54.3	43.9	34.9	29.8	26.1	23.0				
65P-3-210	210		7.5	6.0	5.5	4.4	3.7	3.3	2.9	1.76	5.53	0.56	
80P-3-210			14.5	13.0	11.3	9.0	7.7	6.7	5.9				
105P-3-210			30.0	28.7	23.2	18.4	15.7	13.8	12.1				
130P-3-210			57.0	51.8	41.9	33.3	28.4	24.9	21.9				
65P-3-240	240		7.5	5.8	5.3	4.2	3.6	3.1	2.8	1.76	5.53	0.49	
80P-3-240			14.5	12.6	10.8	8.6	7.4	6.4	5.7				
105P-3-240			30.0	27.6	22.3	17.7	15.1	13.2	11.7				
130P-3-240			57.0	49.9	40.3	32.0	27.4	23.9	21.1				
65P-3-270	270		7.5	5.7	5.1	4.1	3.5	3.0	2.7	1.76	5.53	0.44	
80P-3-270			14.5	12.3	10.4	8.3	7.1	6.2	5.5				
105P-3-270			30.0	26.6	21.5	17.1	14.6	12.8	11.3				
130P-3-270			57.0	48.1	38.9	30.9	26.4	23.1	20.4				

SPECIFICATIONS

Index drive code	Number of stops S	Index period B° [deg]	Static Torque Ms [daN m]	Dynamic output torque Mu [daN m]						Velocity factor Cv	Acceleration factor Ca	Input torque factor K
				Indexes / min.								
				50	100	200	300	400	500			
65P-4-90	4	90	6.0	5.5	5.5	5.4	5.3	5.2	4.9	1.37	6.45	0.73
80P-4-90			13.0	11.8	11.8	11.6	11.3	10.9	10.0			
105P-4-90			27.0	26.3	26.2	25.5	24.5	23.0	20.6			
130P-4-90			52.0	50.0	49.5	47.4	43.9	39.1	32.8			
65P-4-120		120	6.0	4.8	4.8	4.6	4.3	3.8	3.3	1.76	5.53	0.74
80P-4-120			13.0	10.3	10.2	9.9	8.8	7.7	6.8			
105P-4-120			27.0	22.9	22.7	21.3	18.2	15.9	14.0			
130P-4-120			52.0	43.5	43.0	38.5	32.9	28.8	25.4			
65P-4-150		150	6.0	4.9	4.8	4.7	4.0	3.5	3.1	1.76	5.53	0.59
80P-4-150			13.0	10.5	10.4	9.5	8.2	7.1	6.3			
105P-4-150			27.0	23.2	23.1	19.7	16.8	14.7	13.0			
130P-4-150			52.0	44.2	43.7	35.7	30.5	26.6	23.5			
65P-4-180		180	6.0	5.0	4.9	4.4	3.7	3.3	2.9	1.76	5.53	0.49
80P-4-180			13.0	10.7	10.6	8.9	7.6	6.6	2.9			
105P-4-180			27.0	23.7	23.1	18.4	15.7	13.7	12.1			
130P-4-180			52.0	45.0	41.9	33.3	28.5	24.9	22.0			
65P-4-210		210	6.0	5.0	5.0	4.1	3.5	3.1	2.7	1.76	5.53	0.42
80P-4-210			13.0	10.8	10.6	8.4	7.2	6.3	5.5			
105P-4-210			27.0	24.0	21.9	17.4	14.8	13.0	11.5			
130P-4-210			52.0	45.6	39.7	31.5	26.9	23.6	20.8			
65P-4-240		240	6.0	5.0	5.0	4.0	3.4	3.0	2.6	1.76	5.53	0.37
80P-4-240			13.0	10.7	10.2	8.1	6.9	6.0	5.3			
105P-4-240			27.0	23.7	21.0	16.7	14.3	12.5	11.0			
130P-4-240			52.0	44.9	38.1	30.3	25.9	22.6	20.0			
65P-4-270	270	6.0	4.9	4.8	3.8	3.3	2.9	2.5	1.76	5.53	0.33	
80P-4-270		13.0	10.6	9.8	7.8	6.6	5.8	5.1				
105P-4-270		27.0	23.5	20.2	16.1	13.7	12.0	10.6				
130P-4-270		52.0	44.5	36.7	29.2	24.9	21.8	19.2				
65P-6-150	6* *see fig.1b	150	7.5	5.3	5.2	5.0	4.8	4.4	4.0	1.40	6.62	0.63
80P-6-150			14.5	11.4	11.3	10.8	10.1	9.3	8.3			
105P-6-150			30.0	25.2	25.0	24.0	22.5	20.3	18.0			
130P-6-150			57.0	47.8	47.3	45.0	41.3	36.4	30.6			
65P-6-180		180	7.5	5.3	5.2	5.1	4.9	4.5	4.2	1.76	5.53	0.66
80P-6-180			14.5	11.4	11.3	10.9	10.3	9.6	8.7			
105P-6-180			30.0	25.2	25.0	24.1	22.7	20.7	18.3			
130P-6-180			57.0	47.8	47.3	45.1	41.6	36.8	31.0			
65P-6-210		210	7.5	5.3	5.3	5.1	4.9	4.6	4.0	1.76	5.53	0.56
80P-6-210			14.5	11.4	11.4	11.0	10.5	9.3	8.2			
105P-6-210			30.0	25.4	25.2	24.2	21.9	19.1	16.9			
130P-6-210			57.0	48.2	47.7	45.8	39.9	34.9	30.8			
65P-6-240		240	7.5	5.4	5.3	5.2	4.9	4.3	3.8	1.76	5.53	0.49
80P-6-240			14.5	11.6	11.5	11.2	10.0	8.8	7.7			
105P-6-240			30.0	25.8	25.6	24.1	20.6	18.0	15.9			
130P-6-240			57.0	48.9	48.4	44.0	37.6	32.9	29.0			
65P-6-270		270	7.5	5.5	5.5	5.4	4.7	4.1	3.6	1.76	5.53	0.44
80P-6-270			14.5	11.9	11.8	11.2	9.6	8.4	7.4			
105P-6-270			30.0	26.4	26.3	23.1	19.8	17.3	15.3			
130P-6-270			57.0	50.2	49.7	42.2	36.1	31.5	27.8			

Other special motion
can be supplied on request



SPECIFICATIONS

Index drive code	Number of stops S	Index period B° [deg]	Static Torque Ms [daN m]	Dynamic output torque Mu [daN m]						Velocity factor Cv	Acceleration factor Ca	Input torque factor K
				Indexes / min.								
				50	100	200	300	400	500			
65P-8-120	8* *see fig.1b	120	6.0	5.6	5.6	5.5	5.4	5.3	5.1	1.40	6.62	0.59
80P-8-120			13.0	12.1	12.0	11.8	11.5	11.0	10.4			
105P-8-120			27.0	26.9	26.8	26.0	24.8	23.2	21.0			
130P-8-120			52.0	51.2	50.6	48.2	44.2	38.7	31.5			
65P-8-150		150	6.0	5.5	5.5	5.4	5.3	5.2	4.8	1.40	6.62	0.47
80P-8-150			13.0	11.7	11.7	11.6	11.3	11.0	9.7			
105P-8-150			27.0	26.1	26.0	25.5	24.8	23.0	20.3			
130P-8-150			52.0	49.7	49.3	47.7	45.1	41.5	36.8			
65P-8-180		180	6.0	4.2	4.2	4.0	3.9	3.6	3.3	1.76	5.53	0.49
80P-8-180			13.0	9.0	8.9	8.7	8.2	7.6	6.9			
105P-8-180			27.0	20.0	19.9	19.1	18.0	16.5	14.6			
130P-8-180			52.0	38.1	37.7	35.9	33.1	29.3	24.7			
65P-8-210		210	6.0	4.2	4.2	4.1	3.9	3.7	3.4	1.76	5.53	0.42
80P-8-210			13.0	9.1	9.0	8.8	8.3	7.8	7.1			
105P-8-210			27.0	20.2	20.1	19.4	18.4	17.0	15.3			
130P-8-210			52.0	38.5	38.1	36.6	34.1	30.8	26.8			
65P-8-240		240	6.0	4.3	4.3	4.2	4.0	3.8	3.5	1.76	5.53	0.37
80P-8-240			13.0	9.2	9.2	8.9	8.5	8.0	7.2			
105P-8-240			27.0	20.5	20.4	19.8	18.8	14.9	14.9			
130P-8-240			52.0	39.0	38.7	37.3	34.9	30.6	27.0			
65P-8-270			6.0	4.4	4.4	4.3	4.1	3.9	3.4	1.76	5.53	0.33
80P-8-270			13.0	9.5	9.4	9.2	8.8	8.0	7.1			
105P-8-270			27.0	21.1	21.0	20.4	18.9	16.5	14.6			
130P-8-270			52.0	40.1	39.8	38.5	33.9	29.7	26.2			

VERSIONS

The CF3 index drives are normally supplied in the versions illustrated below.

Information on motor systems will be supplied on request.

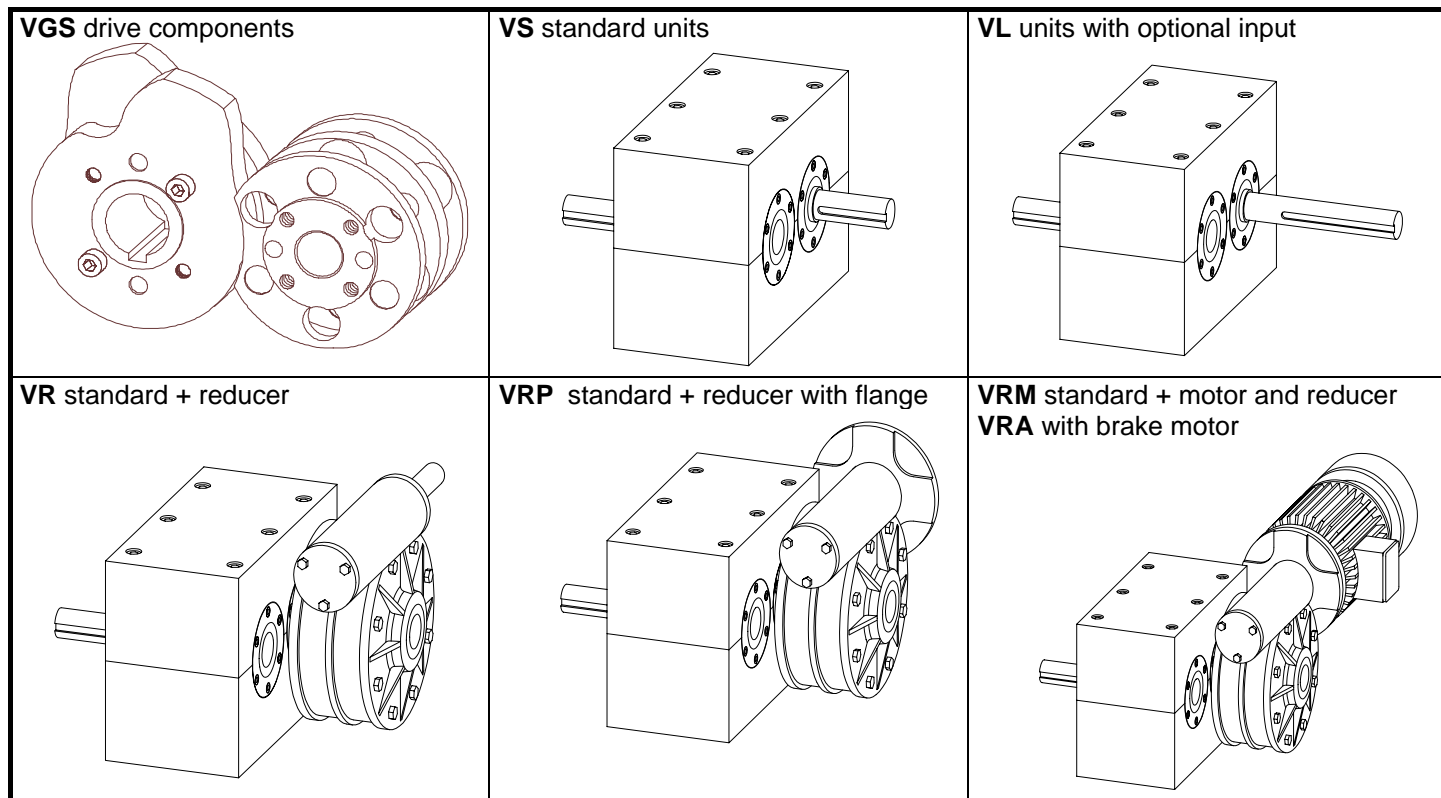

DRIVE COMPONENTS

- Parallel shaft.
- Separate and pre-coupled cam/follower units.
- Cam hub with hollow shaft and keyway.
- High-strength alloy steel cam with hardened, ground profiles.
- Dial plate with central clearance hole and flange mount on each side.
- High load capacity with special yoke-mounted cam followers.



Fig. 1

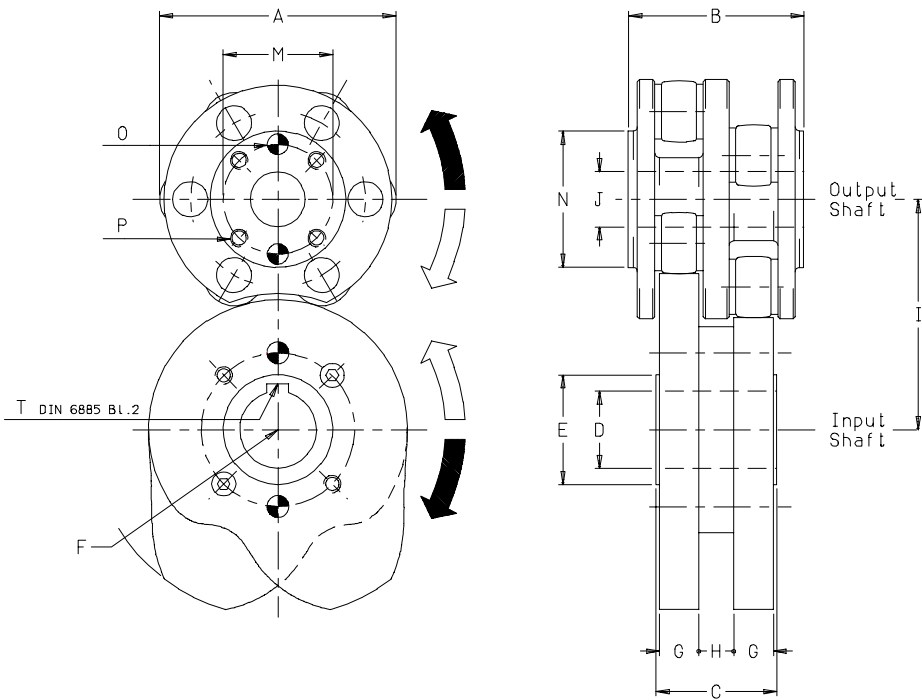
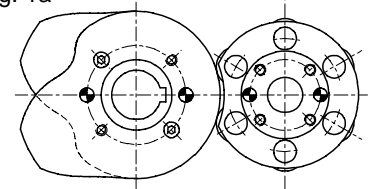
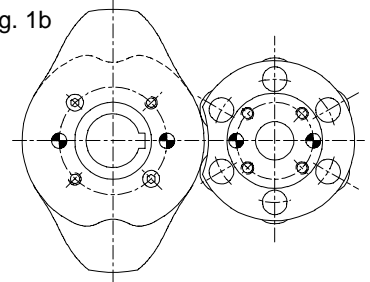

Fig. 1a



The 1/2/3/4 - stops CF3 INDEX DRIVES with complete (360°) input shaft rotation produce 1 cycle (transfer + dwell) of the output shaft. This means that 50 rpm of the input shaft produce 50 indexes/min in output.

Fig. 1b



The 6/8 - stops CF3 INDEX DRIVES with complete (360°) input shaft rotation produce two cycles (transfer + dwell) of the output shaft. This means that 50 rpm of the input shaft produce 100 indexes/min in output.

Series	A	B	C	DH7	Eh6	Fmax	G	H	I	JH7	M	N	O	P	T
65 P	66	40	30	18	30	55	8	10	65	13	25	34	5.5x4.5	M5x4.5	6x6
80 P	82	60	42	28	40	67	13	13	80	18	36	46	7.5x9	M6x9	8x7
105 P	108	80	55	35	50	86	18	16	105	25	50	62	9.5x12	M8x12	10x8
130 P	136	100	66	50	70	107	22	20	130	30	65	79	11.5x16	M10x16	14x9

Notes

- Reversal of the direction of rotation of the input shaft also reverses the direction of rotation of the output shaft, while the kinematic features of the intermittent motion are unchanged.
- The keyway of cam hub "T" is located halfway along the pause stretch.

- The two dowel holes "O" and the four threaded holes "P" are drilled on both sides of the dial plate. The dimensions of holes "O" shown in the table are such as to allow simultaneous boring with the part to be splined at the assembly stage. The holes are located in the positions shown in fig.1, when the INDEX DRIVE is stationary in one of the stations.

- Correct operation of the INDEX DRIVE is guaranteed by the following essential assembly conditions:

- Parallel shafts
- Possibility of pre-loading the followers in the cam pause stretch
- Suitable lubrication of mechanism.

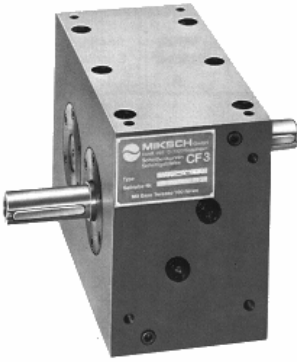

HOUSED UNITS

- Prism-shaped sealed cast iron housing.
- Outer surfaces machined, whit support on 6 sides.
- Possibility of mounting housing in all positions.
- Parallel shafts projecting in input and output.
- Roller bearings on opposite taper roller shafts.
- Oil-bath lubrication.
- Worm gear reducer splined directly to housing.

Fig. 2

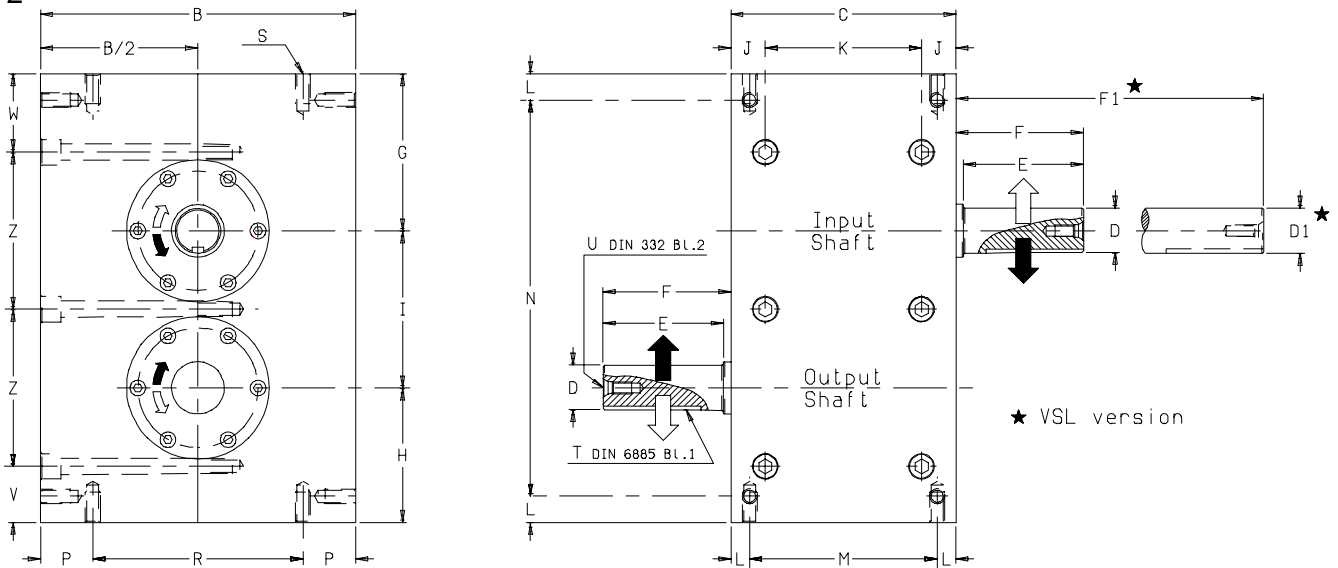

Notes

- Reversal of the direction of rotation of the input shaft also reverses the direction of rotation of the output shaft, while the kinematic features of the intermittent motion are unchanged.
- The input shaft keyway is in the position shown when the INDEX DRIVE is in one of the stations.
- The output shaft keyway is in the position shown when the INDEX DRIVE is in one of the stations.
- The sides containing the input and output shafts can be bored to a maximum depth of 20 mm to eliminate the need for a tiebar joining the two halves of the housing.

Series	A	B	C	D ^{K6}	E	F	G	H	I	J	K	L	M	N
65 P	190	140	95	19	40	43	70	55	65	13	69	7,5	80	175
80 P	240	180	120	28	60	65	90	70	80	17	86	13	95	215
105 P	300	210	150	30	80	85	105	90	105	18	114	18	115	265
130 P	370	260	180	42	110	115	130	110	130	18	144	18	144	334

Series	P	R	S	T	U	V	Z	W	D ₁ ^{h6}	F ₁	Weight [Kg]
65 P	22,5	95	M6x12	6x6x35	M6x16	23	65	38	18	102	12,5
80 P	30	120	M8x15	8x7x55	M10x22	30	80	50	25	145	25
105 P	35	140	M10x20	8x7x75	M10x22	38	105	53	35	180	45
130 P	40	180	M12x25	12x8x10	M16x36	45	130	65	42	210	80

- Housing mounting holes "S" are standard manufacture.
- Correct operation of the CF3 INDEX DRIVE and high quality of motion are obtained by connecting the input and output shafts of the INDEX DRIVE firmly to the machine. For this reason, flexible transmission parts or

parts, which would introduce backlash into the kinematic chain, should not be used.

- Overload protection clutches are effective in safeguarding the CF3 INDEX DRIVE only if fitted to the INDEXDRIVE output shaft.

MOUNTING POSITIONS

The characteristic shape of the housing, and the fully machined outer surfaces and seal enable the CF3 INDEX DRIVE to be mounted in all positions.

In INDEX DRIVE operating at low or medium speed (≤ 150 indexes/min.) lubrication for life is used. The housing is supplied without level window or drain

plugs, ready filled with the right amount of lubricant, requires no maintenance and offers highly flexible assembly. The identification number comprises the code plus indication of the positions of the input and output shafts. In INDEX DRIVE operating at medium and high speeds (> 150 indexes/min.), the oil should be

changed at intervals. The housings are supplied complete with oil inlet/inspection window/outlet plugs and are delivered without lubricant; it is therefore up to the client to fill the housing with the correct amount of oil prior to start-up. The recommended lubricant is AGIP BLASIA 150 OIL. The identification number of these INDEX DRIVE requires a full description of the mounting position with the aid of the chart shown in fig.3.



The oil plugs, when necessary, are positioned diagonally on one of the lateral sides (C,D,E,F) of the housing.

Positions of the oil and mounting holes in the housing other than those illustrated in this catalogue are optional, and must be requested specifically by the client, accompanied by a drawing showing all measurements.

If the order does not contain the identification number of the mounting positions, the housed INDEX DRIVE will be supplied with lubrication for life and shafts in positions 1A and 2B.

Fig.3

	A	B	C	D	E	F
side with input shaft	1	1	2	2	2	2
side with output shaft	2	2	3	3	3	3
side with mounting holes	3	3	4	4	4	4
side with oil plugs	4	4	5	5	5	5
lower side after mounting	5	5	6	6	6	6

 Standard position
  Possible position
  Impossible position

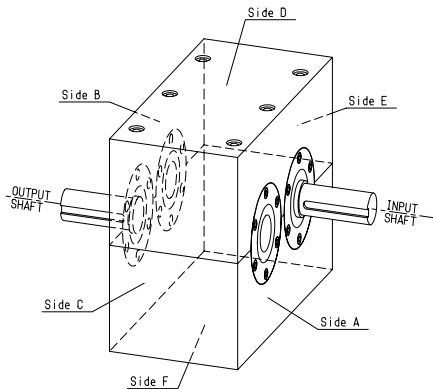

IDENTIFICATION NUMBER

The identification number of the INDEX DRIVE is made up in accordance with the chart.

The mounting position of the worm gear reducer in versions VRS, VSP and VSM is specified in the paragraph "REDUCER MOUNTING POSSIBILITIES".

Example	65P	3	180	VSL	1A	2B	3F	4C	5F
CF3 INDEX DRIVE									
series	_____								
No. of stops	_____								
index period	_____								
version	_____								
side with input shaft	_____								
side with output shaft	_____								
side with mounting holes	_____								
side with oil plugs	_____								
lower side after mounting	_____								

REDUCER MOUNTING POSSIBILITIES

The CF3 INDEX DRIVES in versions VSR VSP and VSM are fitted with worm gear speed reducers suitably selected and splined directly to the input shaft. This system presents a combination of rigid power transmission and a very compact motor driven INDEX DRIVE unit.

The range of reduction ratios available produces speeds between 14 and 200 indexes/min., thereby meeting the majority of application requirements.

The CF3 INDEX DRIVE designed for the worm gear reducer to be splined on, is the VSL long-shaft version.

The reducer can be mounted on the CF3 INDEX DRIVE housing in any of the 8 standard positions shown alongside.

On placing the order, it is necessary to specify, in addition to the reducer mounting position, full details of the type of motor unit required namely:

- reduction ratio of worm gear reducer or number of indexes/min. to be performed by the INDEX DRIVE
- dimensions ISO of the flange when the INDEX DRIVE/REDUCER unit is ordered without motor, but is to be constructed in such a way that a motor can be fitted.
- details of motor: hp, polarity, voltage, frequency etc.

The CF3 INDEX DRIVES also allow various alternative types of motor assembly to be fitted in addition to those described in this catalogue, such as speed variator or brake/clutch units, etc.

If you should require any further information, please do not hesitate to contact us; we shall be pleased to discuss the best way of dealing with your particular requirements.

